

YAMAHA

MIC PREAMPLIFIER PREAMPLIFICATEUR POUR MICROPHONE MIKROFON-VORVERSTÄRKER

HAB

Operation Manual
Manuel d'instructions
Bedienungsanleitung

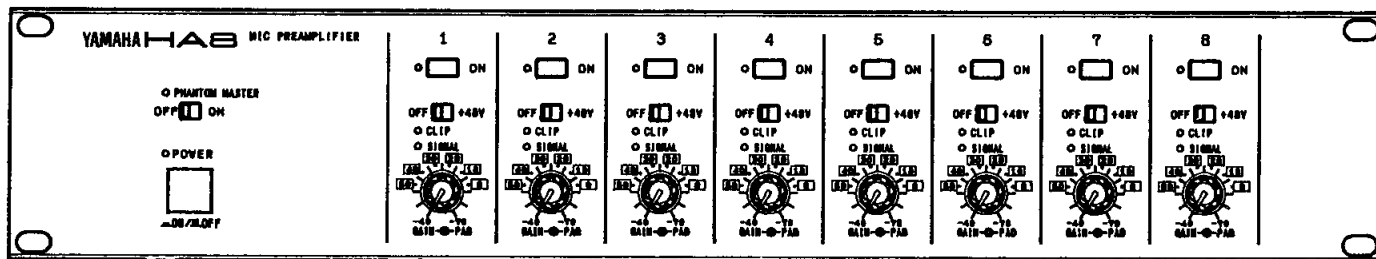

Congratulations on your choice of a Yamaha HA8 8-channel Microphone/Line Amplifier.

The HA8 is designed primarily to add versatile balanced microphone and line input capability to the Yamaha DMP-series Digital Mixing Processors and DMR Digital Multitrack Recorder. In addition to superior overall performance, the HA8 accepts an exceptionally broad range of input signal levels for compatibility with the widest possible range of sources. Each of the 8 amplifiers in the HA8 has a channel mute switch, switchable phantom power, a 5-position pad switch, and a 30 dB gain control. The outputs are +4 dB balanced lines for compatibility with a broad spectrum of professional equipment.

Please read this operation manual thoroughly before operating your HA8.

CONTENTS

PRECAUTIONS	1
CONTROLS AND CONNECTORS	2
FRONT PANEL	2
REAR PANEL	3
SPECIFICATIONS	4
DIMENSIONS	22
BLOCK DIAGRAM / LEVEL DIAGRAM	23

PRECAUTIONS (!! PLEASE READ THIS BEFORE PROCEEDING !!)

1. Avoid Excessive Heat, Humidity, Dust and Vibration

Keep the unit away from locations where it is likely to be exposed to high temperatures or humidity — such as near radiators, stoves, etc. Also avoid locations which are subject to excessive dust accumulation or vibration which could cause mechanical damage.

2. Avoid Physical Shocks

Strong physical shocks to the unit can cause damage. Handle it with care.

3. Do Not Open The Case Or Attempt Repairs Or Modifications Yourself

This product contains no user-serviceable parts. Refer all maintenance to qualified Yamaha service personnel. Opening the case and/or tampering with the internal circuitry will void the warranty.

4. Make Sure Power Is Off Before Making Or Removing Connections

Always turn the power OFF prior to connecting or disconnecting cables.

5. Handle Cables Carefully

Always plug and unplug cables — including the AC cord — by gripping the connector, not the cord.

6. Clean With a Soft Dry Cloth

Never use solvents such as benzine or thinner to clean the unit. Wipe clean with a soft, dry cloth.

7. Always Use the Correct Power Supply

The power requirements for the HA8 are clearly marked on the rear panel. Make sure the specified mains voltage matches the voltage in your area before using the unit!

IMPORTANT NOTICE FOR THE UNITED KINGDOM

Connecting the Plug and Cord

WARNING : THIS APPARATUS MUST BE EARTHED

IMPORTANT. The wires in this mains lead are coloured in accordance with the following code:

GREEN-AND-YELLOW	: EARTH
BLUE	: NEUTRAL
BROWN	: LIVE

As the colours of the wires in the mains lead of this apparatus may not correspond with the coloured markings identifying the terminals in your plug proceed as follows:

The wire which is coloured GREEN-AND-YELLOW must be connected to the terminal in the plug which is marked by the letter E or by the safety earth symbol  or coloured GREEN or GREEN-AND-YELLOW.

The wire which is coloured BLUE must be connected to the terminal which is marked with the letter N or coloured BLACK.

The wire which is coloured BROWN must be connected to the terminal which is marked with the letter L or coloured RED.

CONTROLS AND CONNECTORS

FRONT PANEL

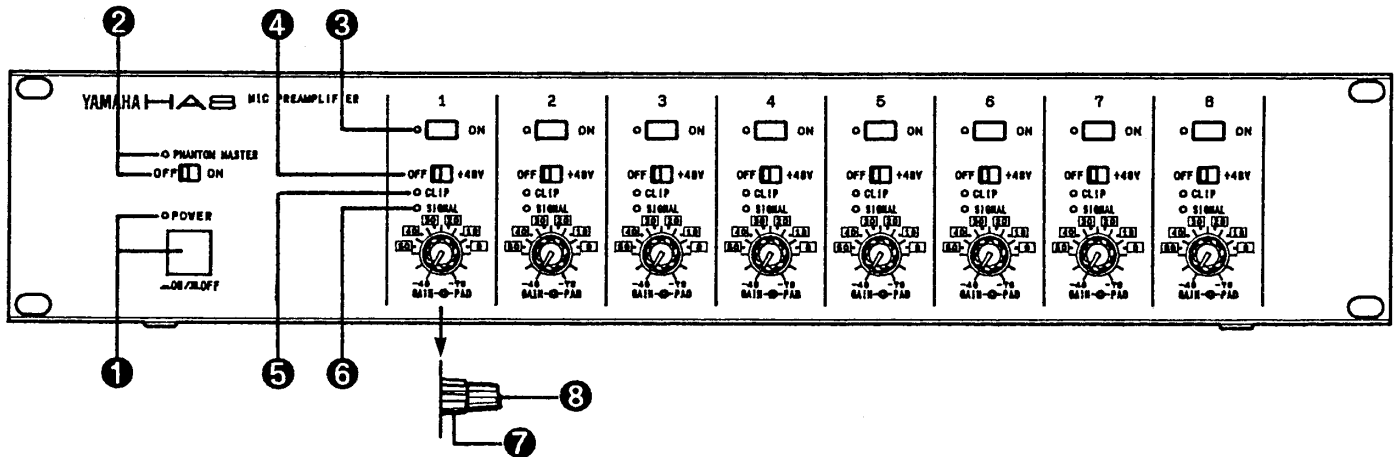

1 POWER Switch & Indicator

Push to turn the HA8 power ON or OFF. The power indicator lights when the power is turned ON.

2 PHANTOM MASTER Switch & Indicator

This is the master phantom power switch for all 8 channels. It should only be turned ON when the HA8 is being used with one or more phantom-powered condenser microphones. When the PHANTOM MASTER switch is ON, its indicator will light and the individual OFF/+48V switches for each channel can be used to apply phantom power to the appropriate inputs. See number 4, below, for more details.

Important!: The PHANTOM MASTER switch setting should **only** be changed after all channel OFF/+48V switches have been set to the OFF position!

3 Channel ON/OFF Switch

These push-ON/push-OFF type switches turn the corresponding channel ON or OFF, completely muting the channel when OFF. Remote channel muting can be accomplished via the rear-panel MUTE CONTROL connector (number 11, below).

4 Channel Phantom OFF/+48V Switch

When the PHANTOM MASTER switch is ON, these switches individually turn phantom power ON (+48V) or OFF for each input. When set to the +48V position, 48 volts DC is applied to the hot and cold signal pins (pins 2 and 3) of the corresponding input connector via 6.8 k Ω current limiting/isolation resistors.

Important!: Make sure that phantom power is turned OFF for inputs that are not connected to phantom-powered condenser microphones.

5 CLIP Indicator

The CLIP indicator is a red LED that lights when the signal in the corresponding channel reaches or exceeds a level 3 dB below clipping. A lit or flashing CLIP indicator means that there is a danger of overloading and distorting that channel, so the signal level should be reduced either by readjusting the HA8 PAD switch and GAIN control, or by reducing the signal level of the source.

6 SIGNAL Indicator

The SIGNAL indicator is a green LED that lights when the signal in the corresponding channel reaches or exceeds 10 dB below the nominal input level. A lit SIGNAL indicator means that the signal applied to that channel is within the range of optimum S/N and distortion performance, as long as the CLIP indicator is not lit.

7 PAD Switch

This five-position pad switch is mounted concentrically with the channel GAIN control, and inserts the marked amount of attenuation prior to the head amplifier of the corresponding channel — 0, 10, 20, 30, 40, or 50 dB. Used in conjunction with the GAIN control described below, the PAD switch allows the input sensitivity of the HA8 to be varied over an extremely wide range.

8 GAIN Control

The GAIN control adjusts the gain of the corresponding channel's head amplifier over a 30 dB range, allowing fine matching between the channel's input sensitivity and the level of the connected source. The actual gain range depends on the setting of the PAD switch, as listed right:

PAD	GAIN RANGE
0	-70dB (0.25mV) — -40dB (7.75mV)
10	-60dB (0.78mV) — -30dB (24.5mV)
20	-50dB (2.45mV) — -20dB (77.5mV)
30	-40dB (7.75mV) — -10dB (245mV)
40	-30dB (24.5mV) — 0dB (0.775V)
50	-20dB (77.5mV) — +10dB (2.45V)

REAR PANEL

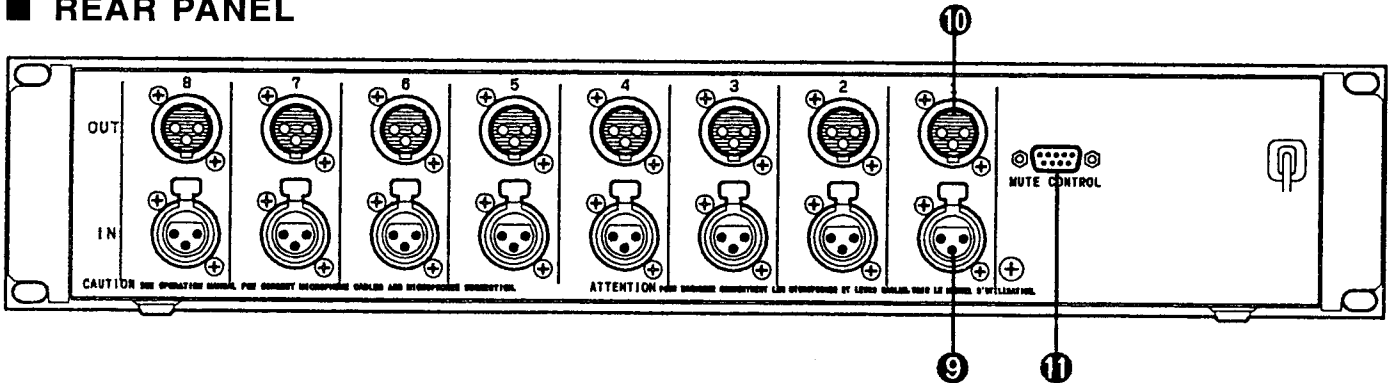

9 IN Connectors 1 through 8

The input connectors to each amplifier channel are XLR-3-31 types wired as follows:

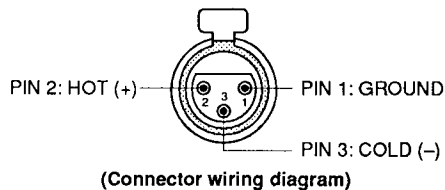

The inputs should be used with 50 — 600 Ω balanced microphones, or 600 Ω balanced lines. Nominal input level depends on the settings of the corresponding PAD switch and GAIN control.

MICROPHONE CABLES AND MICROPHONES CONNECTION

TO PREVENT HAZARD OR DAMAGE, ENSURE THAT ONLY MICROPHONE CABLES AND MICROPHONES DESIGNED TO THE IEC268-15A STANDARD ARE CONNECTED.

10 OUT Connectors 1 through 8

The output connectors from each amplifier channel are XLR-3-32 types wired in the same way as the input connectors.

The outputs should be used to drive 600 Ω balanced

lines. Nominal output level is +4 dB, while the maximum output level before clipping is +24 dB.

11 MUTE CONTROL Connector

The MUTE CONTROL connector allows remote channel muting from a simple switch box or a more sophisticated electronically-controlled relay switching arrangement provided by the user.

Pins 1 through 8 of this 9-pin D-SUB connector control the correspondingly numbered HA8 channels, and pin 9 is ground. Shorting any pin to ground — via a switch or relay — mutes that channel for the duration of the short.

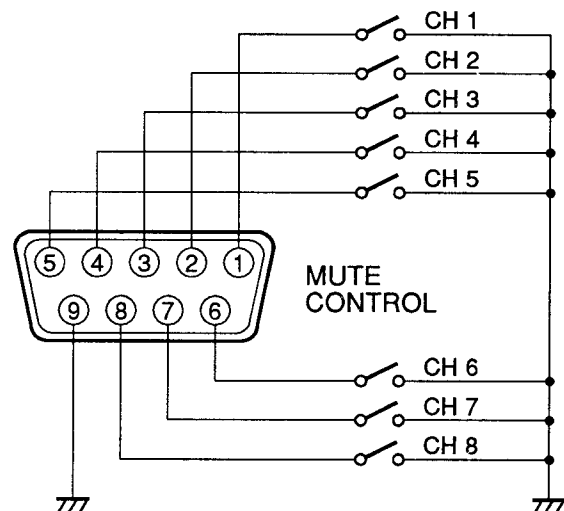

SPECIFICATIONS

Frequency Response	20 Hz — 40 kHz 0 +0.2, -1.0 dB (@ +4 dB, 600 Ω) GAIN: MAX. 20 Hz — 20 kHz 0 +0.2, -0.5 dB (@ +4 dB, 600 Ω) GAIN: MIN.
Total Harmonic Distortion (2nd — 10th) 20 Hz — 20 kHz +14 dB RL = 600 Ω	Less than 0.05 % GAIN: MAX. PAD: 0 dB Less than 0.02 % GAIN: MAX. PAD: 10 dB Less than 0.005 % GAIN: MAX. PAD: 20 dB Less than 0.002 % GAIN: MAX. PAD: 30 dB Less than 0.001 % GAIN: MAX. PAD: 40/50 dB Less than 0.002 % GAIN: MIN. PAD: 0 dB Less than 0.001 % GAIN: MIN. PAD: 10/20/30/40/50 dB
Hum & Noise (20 Hz — 20 kHz) Equivalent Input Noise Rs = 150 Ω	-128 dB (58 dB S/N) GAIN: MAX. PAD: 0 dB Sensitivity = -70 dB -128 dB (68 dB S/N) GAIN: MAX. PAD: 10 dB Sensitivity = -60 dB -128 dB (78 dB S/N) GAIN: MAX. PAD: 20 dB Sensitivity = -50 dB -114 dB (74 dB S/N) GAIN: MAX. PAD: 30 dB Sensitivity = -40 dB -108 dB (78 dB S/N) GAIN: MAX. PAD: 40 dB Sensitivity = -30 dB -102 dB (82 dB S/N) GAIN: MAX. PAD: 50 dB Sensitivity = -20 dB -116 dB (76 dB S/N) GAIN: MIN. PAD: 0 dB Sensitivity = -40 dB -116 dB (86 dB S/N) GAIN: MIN. PAD: 10 dB Sensitivity = -30 dB -115 dB (95 dB S/N) GAIN: MIN. PAD: 20 dB Sensitivity = -20 dB -108 dB (98 dB S/N) GAIN: MIN. PAD: 30 dB Sensitivity = -10 dB -99 dB (99 dB S/N) GAIN: MIN. PAD: 40 dB Sensitivity = 0 dB -89 dB (99 dB S/N) GAIN: MIN. PAD: 50 dB Sensitivity = +10 dB
Maximum Voltage Gain	74 dB (INPUT to OUTPUT)
Crosstalk	-110 dB (@ 1 kHz) adjacent inputs. -90 dB (@ 20 kHz) adjacent inputs. GAIN: MAX. PAD: 20 dB
Control	POWER Switch & Indicator, PHANTOM MASTER Switch & Indicator, Channel ON/OFF Switch, Channel Phantom OFF/+48V Switch, CLIP Indicator, SIGNAL Indicator, PAD Switch, GAIN Control
Signal Indicators	Green LED turn on 10 dB below nominal level.
Clip Indicators	Red LED turn on 3 dB below clipping.
Phantom Power	48 V DC is applied to inputs (via 6.8 kΩ current limiting/isolation resistors) for powering condenser microphones.
MUTE CONTROL Connector	9-pin D-SUB
Power Requirement	U.S. & Canadian Models: 120 V AC, 60 Hz General Model: 220/240 V AC, 50/60 Hz
Power Consumption	U.S. & Canadian Models: 45 W General Model: 45 W
Dimensions (W x H x D)	480 x 88 x 338 mm (18-7/8" x 3-7/16" x 13-5/16")
Weight	7 kg (15 lbs. 7 oz)

* 0 dB = 0.775 Vrms

* The Total Harmonic Distortion figures given above are for the 2nd through 10th harmonics, minus noise components.

* All specifications subject to change without notice.

■ Input Specifications

Input terminal	PAD	GAIN	Actual load impedance	For use with nominal	Input level (@ 1 kHz)			Connector
					Sensitivity *	Nominal	Max. before clip	
INPUT (CH 1 — 8)	0	-70	3 k Ω	50 — 600 Ω Mics & 600 Ω Lines	-70 dB (0.25 mV)	←	-50 dB (2.45 mV)	XLR-3-31 type (Balanced)
	0	-40			-40 dB (7.75 mV)	←	-20 dB (77.5 mV)	
	10				-30 dB (24.5 mV)	←	-10 dB (245 mV)	
	20				-20 dB (77.5 mV)	←	0 dB (0.775 V)	
	30				-10 dB (245 mV)	←	+10 dB (2.45 V)	
	40				0 dB (0.775 V)	←	+20 dB (7.75 V)	
	50				+10 dB (2.45 V)	←	+30 dB (24.5 V)	

* 0 dB = 0.775 Vrms

* Sensitivity is the lowest level that will produce an output of +4 dB (1.23 V)

■ Output Specifications

Output terminal	Actual Source impedance	For use with nominal	Output level		Connector
			Nominal	Max. before clip	
OUTPUT (CH 1 — 8)	150 Ω	600 Ω Lines	+4 dB (1.23V)	+24 dB (12.3 V)	XLR-3-32 type (Balanced)

CAUTION!: Connecting to an AD2X or AD8X

When connecting the HA8 to a Yamaha AD2X or AD8X, use the HA8 controls to set the optimum input level for the AD2X or AD8X. Adjust the HA8 output level using its GAIN and PAD controls, making sure that the CLIP LED does not light.

- The maximum level that can be handled by the AD2X and AD8X head amplifiers is +23.2 dB. Input impedance is 10 k Ω . The HA8 is designed so that its CLIP LED lights when the output level reaches or exceeds +21 dB when driving a 600 Ω load. With a 10 k Ω load, however, the CLIP LED lights at +23 dB. Accordingly, the HA8 CLIP LED also indicates the clipping level of the AD2X or AD8X head amplifier.

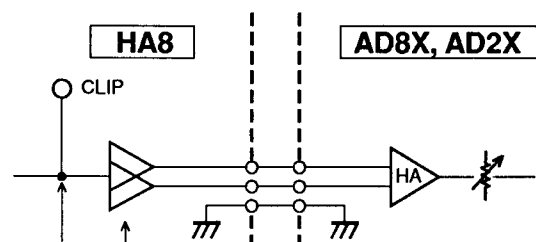

Since the output impedance of this stage is 150 Ω , the actual output level may vary according to the input impedance of the following device.

DIMENSIONS DIMENSIONS ABMESSUNGEN

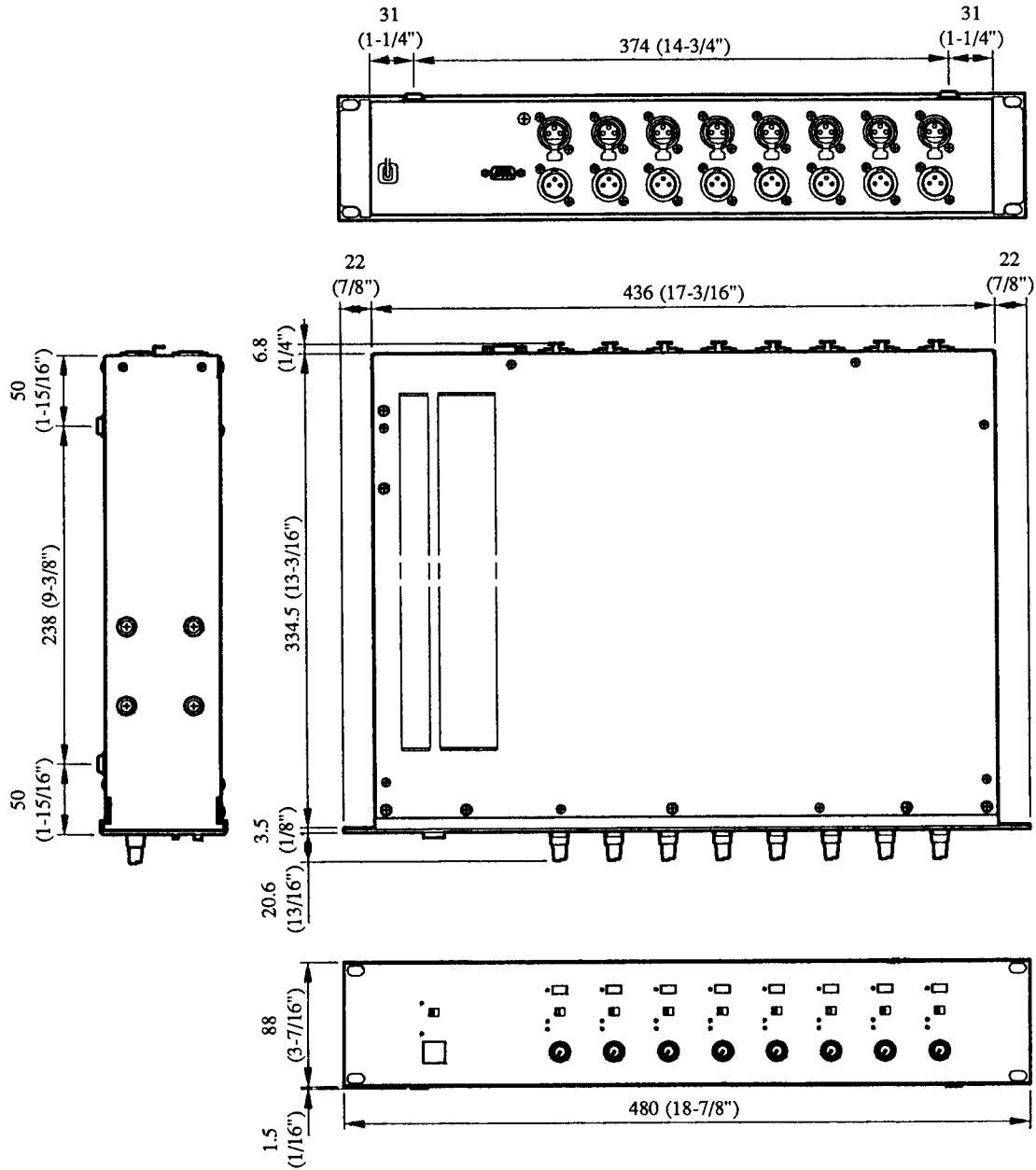

Unit: mm (inch)
 Unité: mm
 Einheit: mm

BLOCK DIAGRAM/LEVEL DIAGRAM SCHEMA DE PRINCIPE/DIAGRAMME DE NIVEAU BLOCK DIAGRAMM/PEGELDIAGRAMM

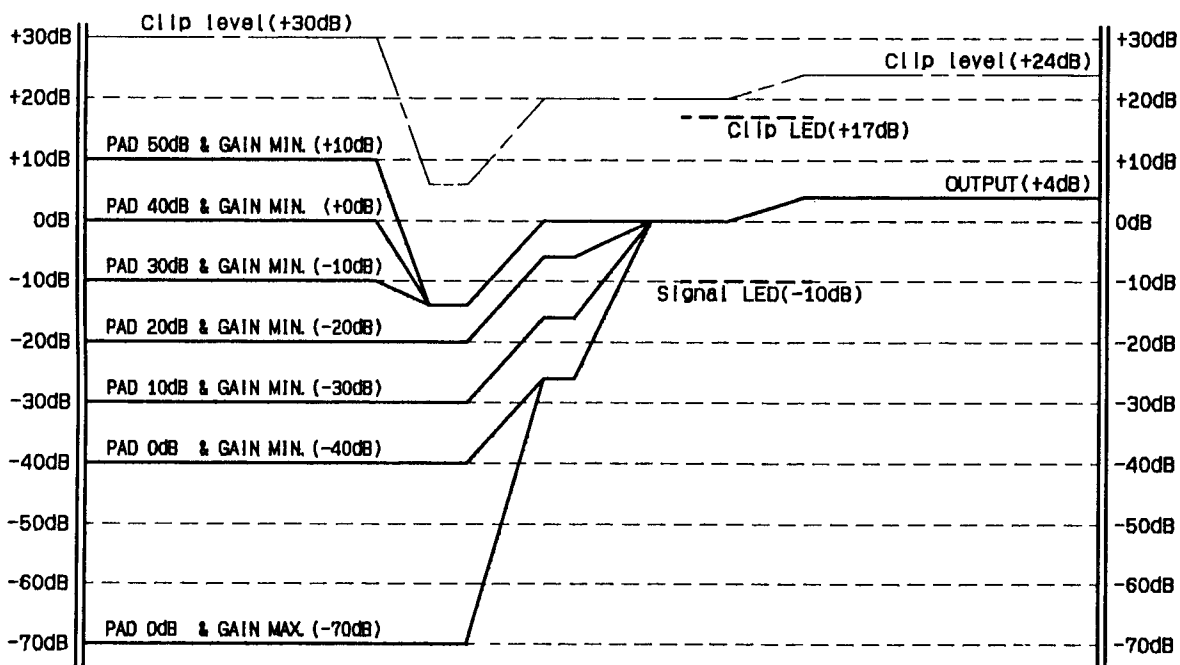
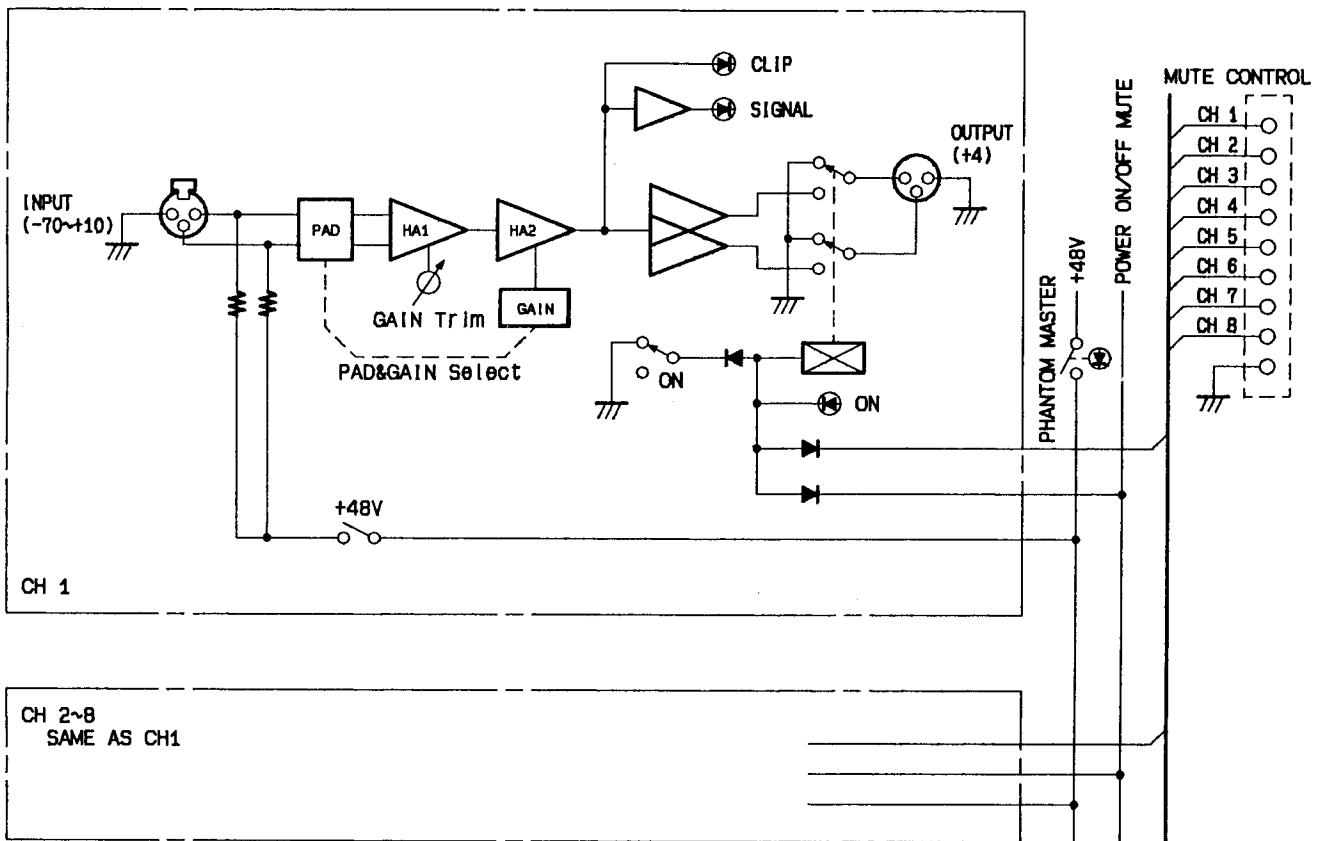

SERVICE

This product is supported by YAMAHA's worldwide network of factory trained and qualified dealer service personnel. In the event of a problem, contact your nearest YAMAHA dealer.

ENTRETIEN

L'entretien de cet appareil est assuré par le réseau mondial YAMAHA de personnel d'entretien qualifié et formé en usine des concessionnaires. En cas de problème, prendre contact avec le concessionnaire YAMAHA le plus proche.

KUNDENDIENST

Für dieses Gerät steht das weltweite YAMAHA Kundendienstnetz mit qualifiziertem, werksgeschultem Personal zur Verfügung. Bei Störungen und Problemen wenden Sie sich bitte an Ihren YAMAHA-Händler.

YAMAHA