

YAMAHA RX-1130 *RS*

Natural Sound Stereo Receiver

125W + 125W (8Ω) RMS Output Power, 0.015%THD, 20-20,000 Hz

16-Station Random Preset Tuning

Computer Servo Lock Tuning with Digital Fine Tuning

Comprehensive 5-Mode Digital Surround Processor

Continuously Variable Loudness Control

Rec-out Selector

CD Direct Switch

High Dynamic Power, Low Impedance Drive Capability

Programmable Remote Control Transmitter

Thank you for selecting the YAMAHA model RX-1130 Stereo Receiver.

CENTER

OWNER'S MANUAL



CONTENTS

Safety Instructions	2
Caution	3
Supplied Accessories	9
Control Parts and Their Functions	9
Connections	12
Operations	15
Using the Surround Sound Processor	17
Remote Control Transmitter	19
Troubleshooting	25
Specifications	26

IMPORTANT!

Please make a note of the serial number of this unit in the space indicated below.

Model: **RX-1130**

Serial No.:

The serial number is inscribed on the rear of the unit. Keep this Owner's Manual in a safe place for future reference.

SAFETY INSTRUCTIONS

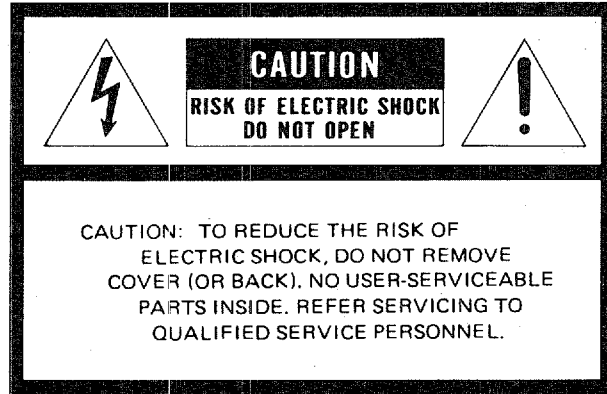

• Explanation of Graphical Symbols



The lightning flash with arrowhead symbol, within an equilateral triangle, is intended to alert you to the presence of uninsulated "dangerous voltage" within the product's enclosure that may be of sufficient magnitude to constitute a risk of electric shock to persons.

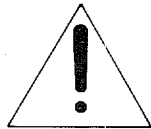

The exclamation point within an equilateral triangle is intended to alert you to the presence of important operating and maintenance (servicing) instructions in the literature accompanying the appliance.

WARNING

To reduce the risk of fire or electric shock, do not expose this appliance to rain or moisture.

1 Read Instructions – All the safety and operating instructions should be read before the appliance is operated.

2 Retain Instructions – The safety and operating instructions should be retained for future reference.

3 Heed Warnings – All warnings on the appliance and in the operating instructions should be adhered to.

4 Follow Instructions – All operating and other instructions should be followed.

5 Water and Moisture – The appliance should not be used near water – for example, near a bathtub, washbowl, kitchen sink, laundry tub, in a wet basement, or near a swimming pool, etc.

6 Carts and Stands – The appliance should be used only with a cart or stand that is recommended by the manufacturer.

6A An appliance and cart combination should be moved with care. Quick stops, excessive force, and uneven surfaces may cause the appliance and cart combination to overturn.



7 Wall or Ceiling Mounting – The appliance should be mounted to a wall or ceiling only as recommended by the manufacturer.

8 Ventilation – The appliance should be situated so that its location or position does not interfere with its proper ventilation. For example, the appliance should not be situated on a bed, sofa, rug, or similar surface, that may block the ventilation openings; or placed in a built-in installation, such as a bookcase or cabinet that may impede the flow of air through the ventilation openings.

9 Heat – The appliance should be situated away from heat sources such as radiators, stoves, or other appliances that produce heat.

10 Power Sources – The appliance should be connected to a power supply only of the type described in the operating instructions or as marked on the appliance.

11 Power-Cord Protection – Power-supply cords should be routed so that they are not likely to be walked on or pinched by items placed upon or against them, paying particular attention to cords at plugs, convenience receptacles, and the point where they exit from the appliance.

12 Cleaning – The appliance should be cleaned only as recommended by the manufacturer.

13 Nonuse Periods – The power cord of the appliance should be unplugged from the outlet when left unused for a long period of time.

14 Object and Liquid Entry – Care should be taken so that objects do not fall into and liquids are not spilled into the inside of the appliance.

CAUTION : READ THIS BEFORE OPERATING YOUR UNIT

15 Damage Requiring Service – The appliance should be serviced by qualified service personnel when:

- A.** The power-supply cord or the plug has been damaged; or
- B.** Objects have fallen, or liquid has been spilled into the appliance; or
- C.** The appliance has been exposed to rain; or
- D.** The appliance does not appear to operate normally or exhibits a marked change in performance; or
- E.** The appliance has been dropped, or the cabinet damaged.

16 Servicing – The user should not attempt to service the appliance beyond those means described in the operating instructions. All other servicing should be referred to qualified service personnel.

17 Power Lines – An outdoor antenna should be located away from power lines.

18 Grounding or Polarization – The precautions that should be taken so that the grounding or polarization of an appliance is not defeated.

19 Outdoor Antenna Grounding – If an outside antenna is connected to the receiver, be sure the antenna system is grounded so as to provide some protection against voltage surges and built up static charges.

Section 810 of the National Electrical Code, ANSI/NFPA No. 70-1984, provides information with respect to proper grounding of the mast and supporting structure, grounding of the lead-in wire to an antenna discharge unit, size of grounding conductors, location of antenna-discharge unit, connection to grounding electrodes, and requirements for the grounding electrode.

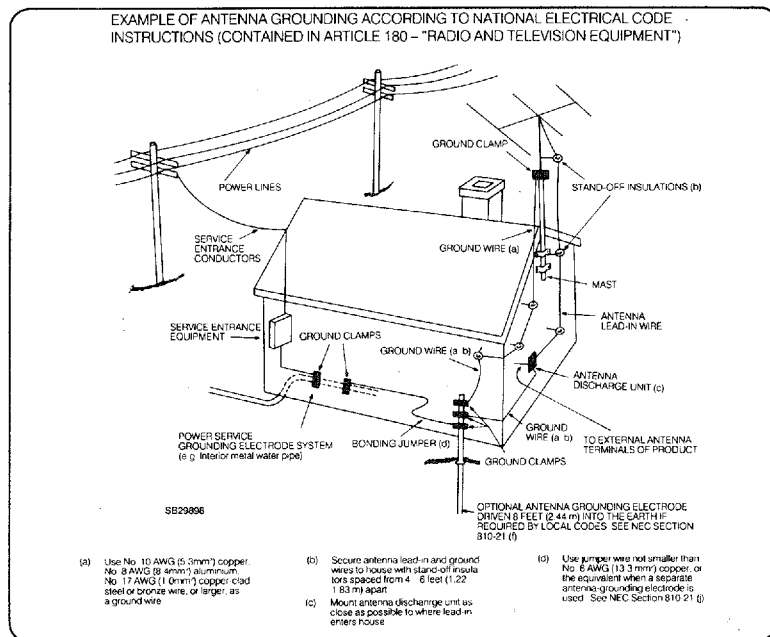

- 1.** This unit is a sophisticated receiver. To ensure proper operation for the best possible performance, please read this manual carefully.
- 2.** Choose the installation location of this unit carefully. Avoid placing it in direct sunlight or close to a source of heat. Also avoid locations subject to vibration and excessive dust, heat, cold or moisture. Keep it away from such sources of hum as transformers or motors.
- 3.** Do not open the cabinet as this might result in damage to the set, or electrical shock. If a foreign object should get into the set, contact your dealer.
- 4.** To prevent lightning damage, pull out the power cord and remove the antenna cable during an electrical storm.
- 5.** When removing the power plug from the wall outlet, always pull directly on the plug; never pull the cord itself.
- 6.** Do not use force when using the switches.
- 7.** When moving the set be sure to first pull out the power plug and remove cords connected to other equipment.
- 8.** Do not attempt to clean this unit with chemical solvent as this might damage the finish. Use a clean, dry cloth.
- 9.** Be sure to read the "Troubleshooting" section for advice on common operating errors before concluding that this unit is faulty.
- 10.** Keep this manual in a safe place for future reference.

1 SUPPLIED ACCESSORIES

● Remote Control Transmitter

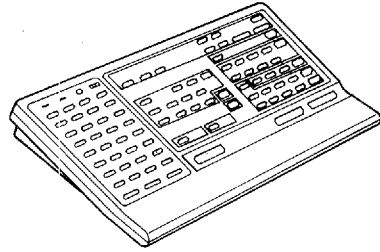

● Batteries (size "AA" R06)

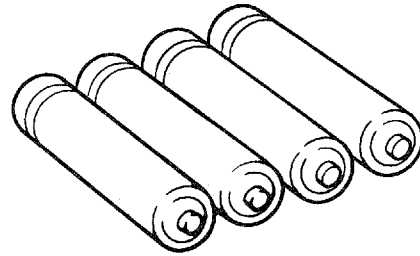

● AM Loop Antenna

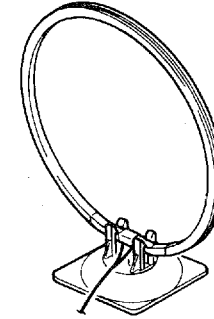

● Indoor FM Antenna

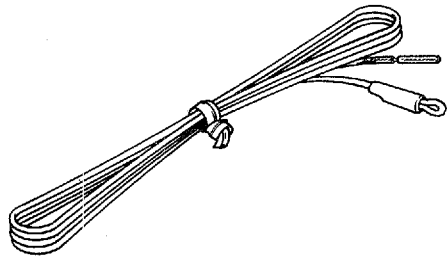

● Remote Control Cable (6-pin. cassette deck)

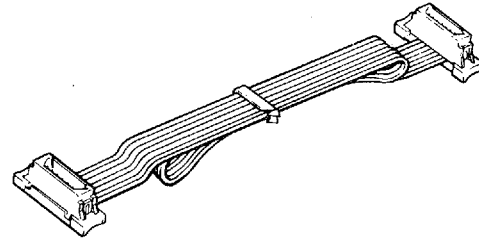

● Remote Control Cable (mini-plug, turntable)

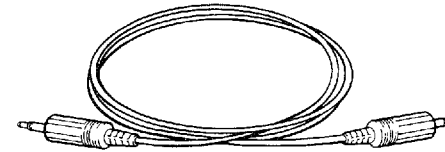

2 FRONT PANEL

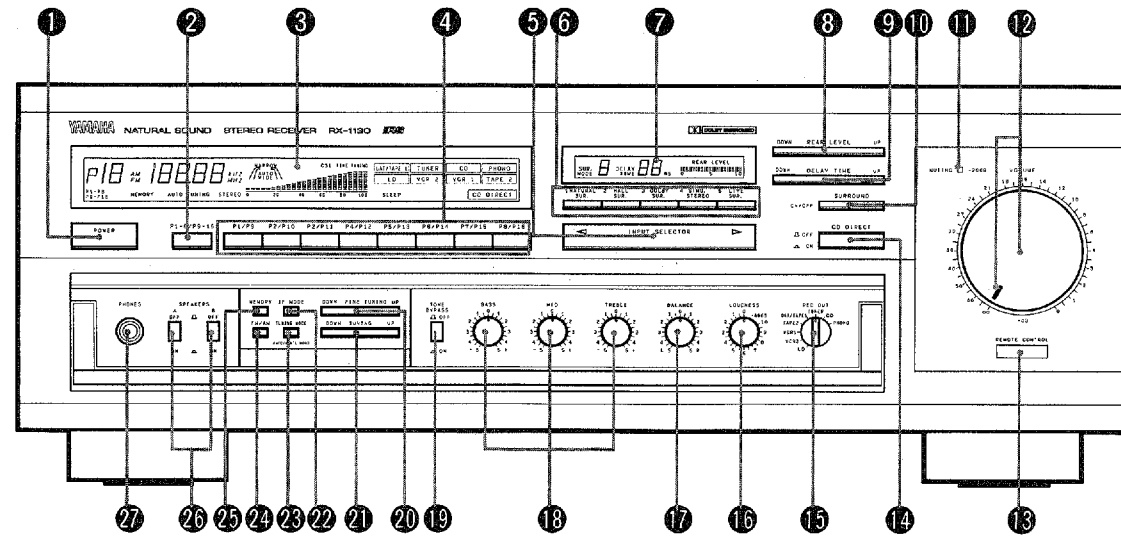

3 Display window

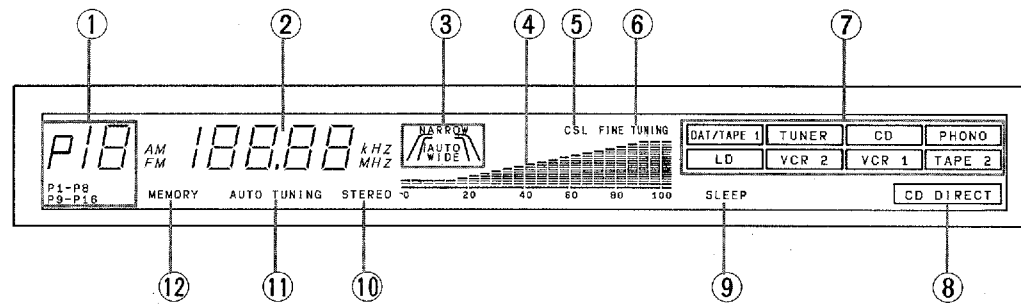

REAR PANEL

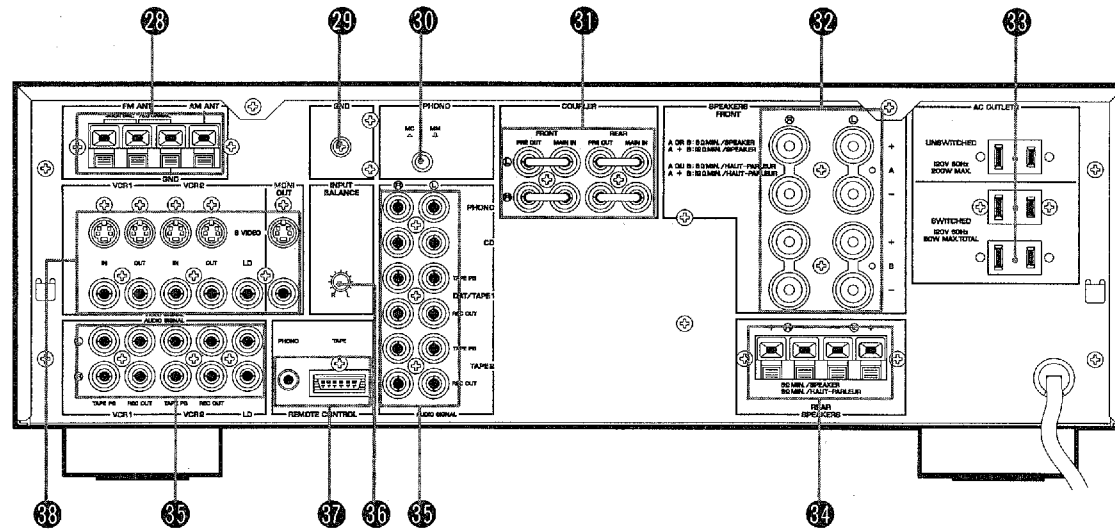

3 ANTENNA CONNECTIONS

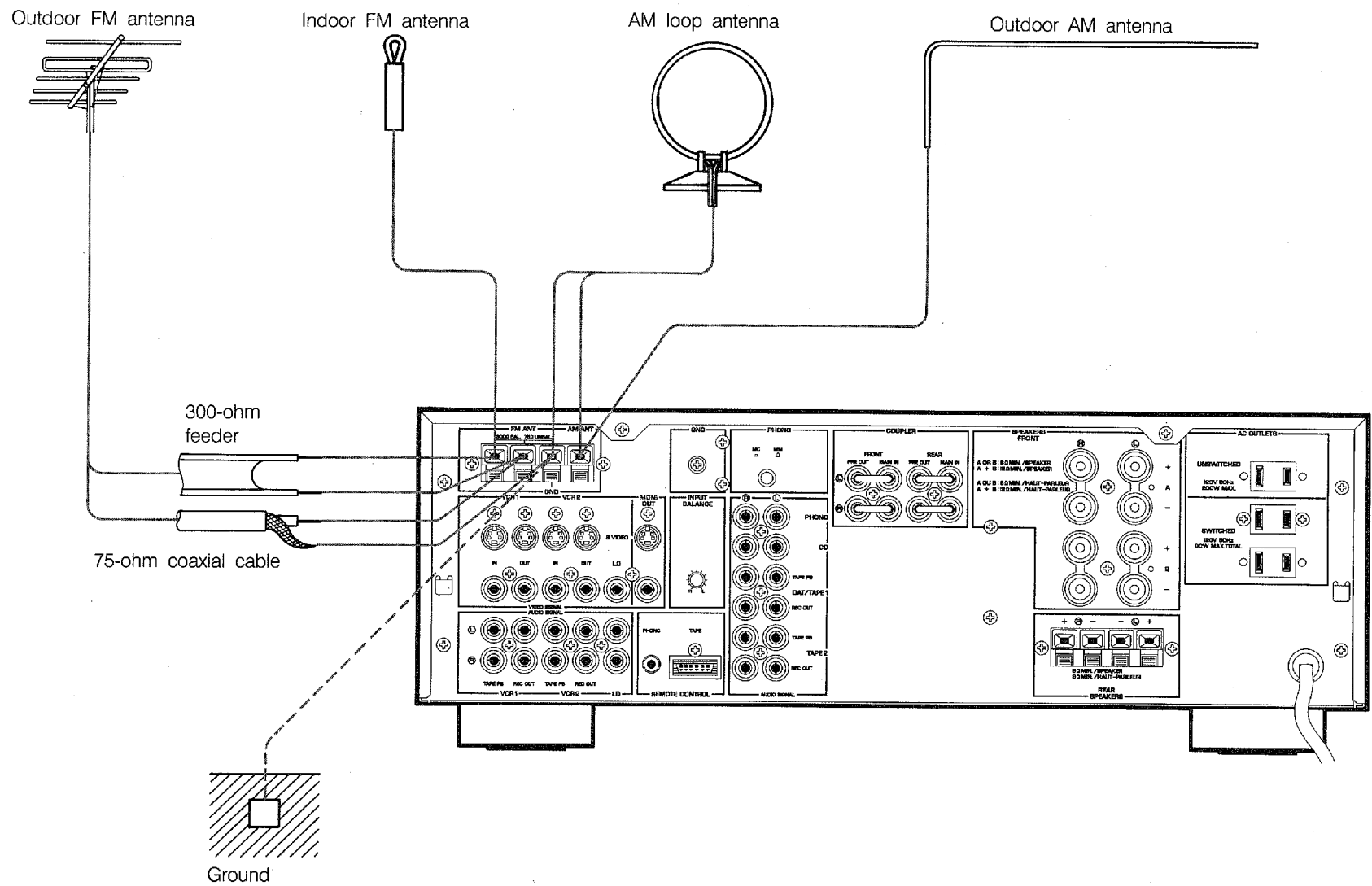

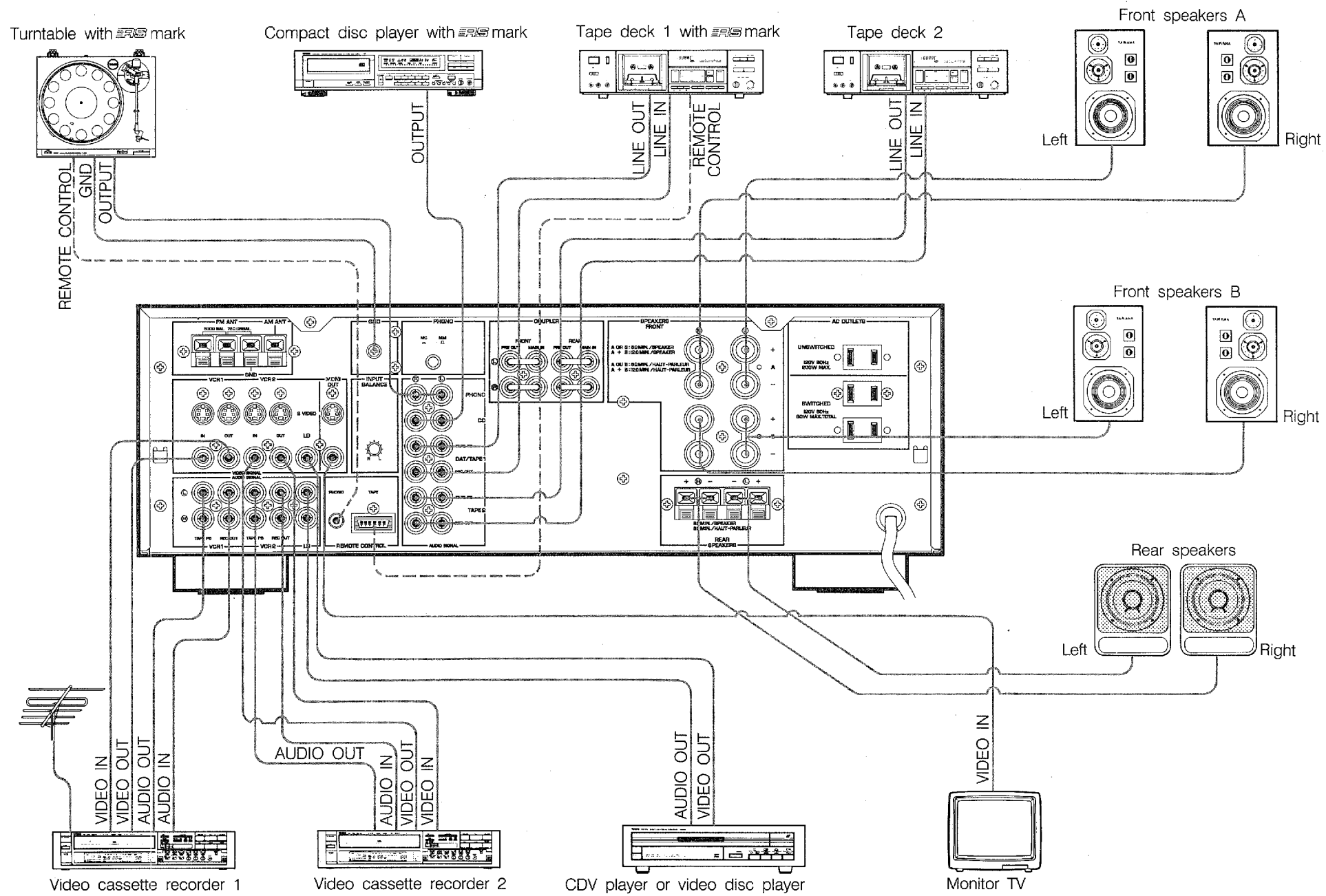

5 REAR SPEAKER PLACEMENT

A

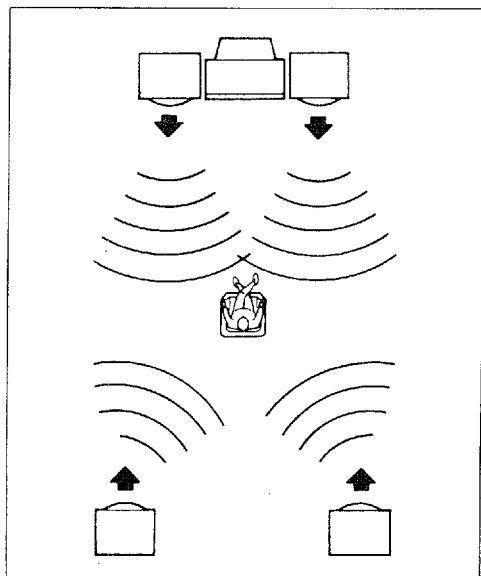

B

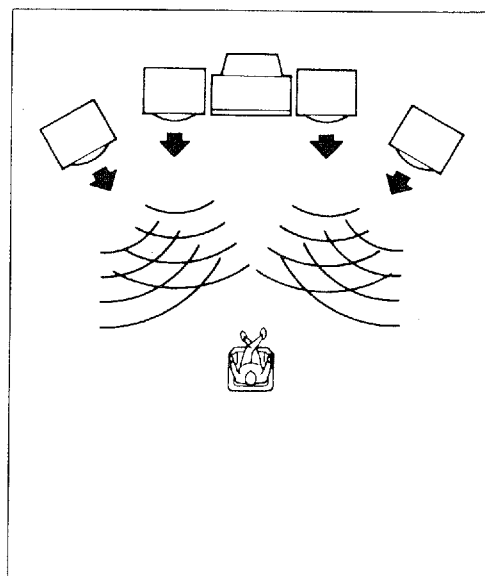

C

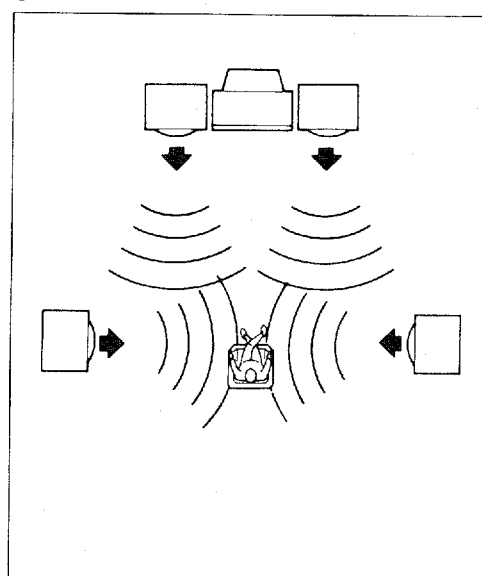

SUPPLIED ACCESSORIES

(See Fig. 1.)

After unpacking, check that the following parts are provided.

- Remote control transmitter
- Batteries
- Remote control cable (6-pin)
- Remote control cable (mini-plug)
- AM loop antenna
- Indoor FM antenna

CONTROL PARTS AND THEIR FUNCTIONS

(See Fig. 2.)

FRONT PANEL

① POWER switch

Press this switch to turn the power on. Press the switch again to turn the power off.

② P1-P8/P9-P16 button

Press this button to change the range of preset station buttons. When this button is pressed, the selected range of the P1-P8/P9-P16 indicators flickers for about 5 seconds.

③ Display window

① PRESET display

Preset station indicator

Lights up to indicate the pressed preset station button.

P1-P8/P9-P16 indicators

Indicates the range (either P1-P8 or P9-P16) of selectable preset station buttons.

② STATION FREQUENCY display

Displays the band and frequency of the received radio signal.

③ IF MODE AUTO/NARROW/WIDE indicator

AUTO:
When the Auto Mode is selected with the IF MODE button, this indicator lights.

NARROW or WIDE:

When the NARROW or WIDE Mode is selected with IF MODE button, the corresponding indicator lights.

④ SIGNAL QUALITY indicators

These indicators display the signal strength of the tuned frequency in bar-graph form. 0 marks a poor or no signal, while 100 indicates an excellent signal.

⑤ CSL (Computer Servo Lock)

This indicator lights when the Computer Servo Lock (CSL) system is activated during FM reception mode. For details, refer to "Technical notes on the Computer Servo Lock (CSL) system" described on page 15.

⑥ FINE TUNING

When the FINE TUNING button is operated, this indicator lights.

⑦ INPUT indicator

Indicates the program source selected by the Input selector.

⑧ CD DIRECT indicator

Lights up while the CD DIRECT switch is set to ON.

⑨ SLEEP indicator

This indicator illuminates beginning from the time that the SLEEP key of the remote-control transmitter is pressed and until the SLEEP mode is automatically canceled one hour later.

⑩ STEREO indicator

When an FM stereo signal of sufficient strength is received the STEREO indicator lights up.

⑪ AUTO TUNING indicator

When the tuner is in automatic tuning mode, the AUTO TUNING indicator lights.

⑫ MEMORY indicator

When the MEMORY button is pressed, the MEMORY indicator blinks on and off.

⑬ Preset station buttons

Up to 16 station frequencies and reception modes can be stored using the preset station button.

⑭ Input selector (INPUT SELECTOR)

Used to select the program source to be heard. The selected program source is indicated in the display.

6 SURROUND MODE buttons

These modes are effective only when this unit is driving a rear speaker pair in a 4-speaker system. These buttons are used to implement the following 5 surround sound features.

- | | |
|--------------------|-----------------|
| 1 Natural Surround | 4 Simulated |
| 2 Hall Surround | Stereo |
| 3 Dolby Surround | 5 Live surround |

Press one of these buttons to select one of the 5 surround modes.

7 SURROUND MODE display

SURROUND MODE:

Displays the surround mode selected with the SURROUND MODE buttons.

DELAY TIME:

Displays the delay time from 10 mS to 30 mS, set with the DELAY TIME control.

8 REAR LEVEL volume control

This control raises or lowers the volume level of the rear speakers. Press the UP side of the control to raise the volume level and press the DOWN side to lower it.

9 DELAY TIME control

This control is used to vary the audio sound delay time, from 10 mS to 30 mS, to the rear speaker pair.

10 SURROUND ON/OFF switch

Set this switch to ON to enable the surround mode features. The SURROUND MODE display appears. When surround mode is not desired, set this switch to OFF. The SURROUND MODE display disappears.

11 Audio MUTING indicator

This indicator lights when Muting is engaged (from the remote control unit). By pressing the MUTING (-20 dB) key of the remote control transmitter, the sound level will be muted by 20 dB.

12 VOLUME control and indicator

This control is used to raise or lower the output volume level.

13 REMOTE CONTROL sensor

This is used to receive signals from the remote control transmitter.

14 CD DIRECT SWITCH (CD DIRECT)

This switch allows you to route the CD input signal directly to the output stage bypassing the Input selector, Surround sound processor, Loudness, and Balance controls therefore avoiding any "muddying" caused by the switch and circuit routing to provide a pure sound.

15 REC OUT selector

Used to select the program source to be recorded.

16 Continuous variable LOUDNESS control

This control allows you to retain full tonal range at any volume levels. Your ear loses sensitivity to high and low frequency ranges at low volume settings. This control provides an equalization curve based on human hearing.

To adjust the LOUDNESS control to your listening level, first, set the control to the FLAT position, increase the VOLUME control to your loudest listening level, then turn the LOUDNESS control counterclockwise to reduce the volume level.

17 BALANCE control

Use this control to concurrently change the left and right output volume to the speaker terminals to compensate for sound imbalance caused from speaker settings or listening room condition.

18 Tone controls

BASS control:

This control is used to increase or decrease the low frequency response. The "0" center click position produces a flat response. Rotating the control in the + direction increases the low frequency response. Conversely, rotating the control in the - direction decreases it.

MID control:

This control is used to increase or decrease the mid-range frequency response. The "0" center click position produces a flat response. Rotating the control in the + direction increases the mid-range frequency response. Conversely, rotating the control to the - direction decreases it.

TREBLE control:

This control is used to increase or decrease the high frequency response. The "0" center click position produces a flat response. Rotating the control in the + direction increases the high frequency response. Conversely, rotating the control in the - direction decreases it.

19 TONE BYPASS switch

When this switch is set to ON, the input signal does not pass through the tone control circuitry so that it is unaffected by the tone control circuitry.

Use this switch to obtain pure sound and to check the tone control setting.

Set this switch to OFF to activate the tone control circuitry.

20 FINE TUNING button

Press either side of this button to precisely tune the station with Manual tuning.

When this button is pressed, the displayed frequency changes by 0.01 MHz for FM and 1 kHz for AM band.

21 TUNING button

Press either side of the TUNING button to carry out auto or manual tuning.

22 IF MODE button

Used to vary the band pass width of the FM intermediate frequency, between WIDE and NARROW.

AUTO:

When the AUTO IF Tuning mode is selected, the AUTO indicator lights and the tuner automatically selects the IF band pass width.

NARROW/WIDE:

Select the NARROW or WIDE IF Tuning mode pressing this button.

When the reception signal is strong, press this button so that the WIDE indicator lights to obtain distortion-free sound. When the reception signal is weak, or when the desired station is interfered with by adjacent stations, press this button so that the NARROW indicator lights to increase the selectivity.

23 TUNING MODE button

Used to select the tuning mode between AUTO and MAN'L MONO. In the MAN'L MONO mode, an FM stereo broadcasting is received in monaural.

24 FM/AM button

Press this button to select the reception band between FM and AM.

25 MEMORY button

When this button is pressed, the MEMORY indicator flickers in the display for about 5 seconds. During this period, press the desired preset station button to store the displayed frequency.

26 SPEAKERS selectors

Set this selector to select the front speakers A or B to be driven.

27 PHONES jack

Plug in the headphones to this jack. To shut off the sound from the speakers, set the SPEAKERS selectors to OFF.

REAR PANEL

28 Antenna terminals

Connect an FM and AM antennas to these terminals.

29 GND terminal

Connect the ground wire of a turntable.

30 PHONO selector

Set this selector according the type of the cartridge, MM (moving magnet) or MC (moving coil) used in your turntable.

31 COUPLER

PRE OUT/MAIN IN jacks

For extra system flexibility, this unit allows you to connect a signal processing system, such as a graphic equalizer or sound processor. For connection of each unit, refer to the Owner's Manual attached to the unit to be connected.

32 FRONT SPEAKERS terminals

Two pairs of front speakers A and B can be connected to these terminals.

33 AC OUTLETS

Use these to connect the power cords from your components to the receiver.

The power to the SWITCHED outlets is controlled by the receiver's POWER switch or remote control transmitter's POWER key. They will supply power to any component whenever this unit is turned on.

The power to the UNSWITCHED outlet is not controlled by the receiver. It will continually supply power to any unit connected.

The maximum power that can be connected to the SWITCHED AC OUTLET is 80 watts and to the UNSWITCHED AC OUTLET is 200 watts.

34 REAR SPEAKERS terminals

A pair of rear speakers can be connected to these terminals.

35 Audio signal connection jacks

Use these to connect the audio signal cords from your components to the receiver. They should be connected to the proper input/output jacks for each unit. Be sure that L and R channels are connected consistently.

PHONO

Connect a turntable.

CD

Connect a compact disc player.

DAT/TAPE 1

Connect a first tape deck for both recording and playback.

TAPE 2

Connect a second tape deck for both recording and playback.

VCR 1

Connect a first video cassette recorder for both recording and playback.

VCR 2

Connect a second video cassette recorder for both recording and playback.

LD

Connect a CDV player or a video disc player.

36 INPUT BALANCE control

Use this control to obtain the best surround condition. For details of the surround condition adjustment, refer to page 18.

37 REMOTE CONTROL connectors

Use these to connect compatible YAMAHA components (with an *RS* mark) to your receiver for remote control of each component.

PHONO

Connect to a turntable using the cable with a mini-plug connectors.

TAPE

Connect to a cassette tape deck using the cable with 6-pin connector.

CONNECTIONS

VIDEO SIGNAL jacks

Use these to connect the video signal cords from your components to the receiver. They should be connected to the proper input/output jacks for each unit.

VCR 1

Connect a first video recorder for both recording and playback.

VCR 2

Connect a second video recorder for both recording and playback.

LD

Connect a CDV player or a video disc player.

MONI OUT

Connect a monitor TV.

S VIDEO connectors

* With the S VIDEO connections, a high resolution picture will be obtained, resulting in a much clearer reproduction.

S VIDEO VCR 1 connectors – Connect to a Video Cassette Recorder that has S connectors for both recording and playback.

S VIDEO VCR 2 connectors – Connect to a second Video Cassette Recorder that has S connectors for both recording and playback.

S VIDEO MONI OUT connector – Connect to the S input connector on a video monitor.

NOTE ON CONNECTIONS

Be sure to turn off the power to all units before making any connections.

ANTENNA CONNECTIONS

(See Fig. 3.)

• AM loop antenna

Connect the AM loop antenna cords to the AM ANT and GND terminals.

- ① Depress the tabs of AM ANT terminals.
- ② Connect the AM loop antenna leads to the AM ANT terminals.
- ③ Release the tabs. Lightly pull on the leads to confirm a good connection.

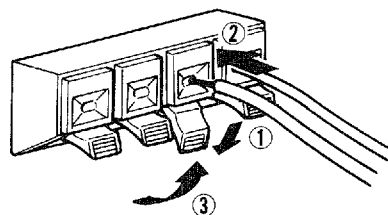

- ④ Attach the AM loop antenna to the antenna stand.

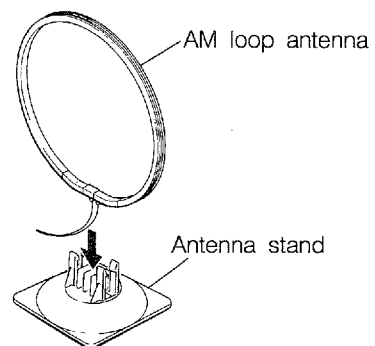

- ⑤ Orient the AM loop antenna so that the best reception is obtained.

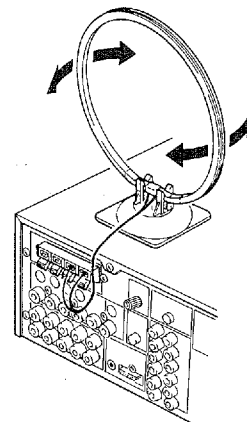

* The antenna may be hung on a wall.

• Outdoor AM antenna

The end of the wire should be stripped of insulation and connected to the AM ANT terminal. At this time, keep the loop antenna connected.

• Supplied indoor FM antenna

Connect the supplied indoor antenna to either of the 300 Ω BAL. FM ANT terminals. Move the antenna for best reception.

• Outdoor FM antenna

If necessary an outdoor FM antenna may be used for improved FM reception. Either 300-ohm feeder or coaxial cable may be used. In locations troubled by electrical interference, coaxial cable is preferable.

AUDIO/VIDEO CONNECTIONS

(See Fig. 4.)

● Power cord

Connect the power cord of your receiver to an AC outlet.

● Speakers

Connections for the FRONT SPEAKERS terminals

Turn the SPEAKER terminal connectors to loosen them, insert the stripped wire into the hole of the terminals, and then turn the connector clockwise until firm. The wires will be locked into position. If these connections are faulty, no sound will be heard from the speakers.

* Speaker cords with Banana Plugs can also be used.

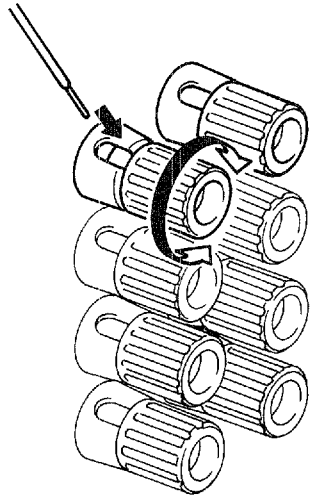

Red is positive, black is negative

Connections for the REAR SPEAKERS terminals

Press the SPEAKER terminal tabs down, then insert the stripped wires and secure them by releasing the tabs. If these connections are faulty, no sound will be heard from the speakers.

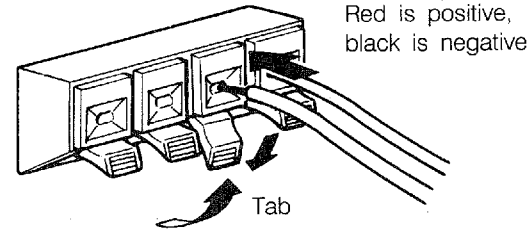

● Turntable

Connect the output cords of the turntable to the PHONO jacks, and connect the ground cord to the GND terminal. This should produce minimum hum, but in some cases better results are obtained with this cord disconnected.

● Compact disc player

Connect the output jacks of the compact disc player to the CD jacks.

● CDV/Video disc player

Connect the video output jack from a CDV player or a video disc player to the LD (VIDEO SIGNAL) jack. Connect the audio output jacks from a CDV player or a video disc player to the LD (AUDIO SIGNAL) jacks.

● Tape deck

Connect the cable from a cassette deck, or other audio tape unit, to the DAT/TAPE 1 jacks, and connect a second cassette deck, or another audio tape unit, to the TAPE 2 jacks. The playback (LINE OUT) jacks of the cassette deck go to the TAPE PB jacks, and the record (LINE IN) jacks go to the REC OUT jacks on the rear panel of this unit.

● VCR (Video cassette recorder)

Connect the video jacks of the VCR to the VCR 1 (VIDEO SIGNAL) jacks, and connect the video jacks of a second VCR to the VCR 2 (VIDEO SIGNAL) jacks on the rear panel of this unit. The video playback (VIDEO OUT) jack of the VCR goes to the IN jack, and the video record (VIDEO IN) jack goes to the OUT jack.

Connect the audio output jacks of the VCR to the VCR 1 (AUDIO SIGNAL) jacks, and connect the audio output jacks of a second VCR to the VCR 2 (AUDIO SIGNAL) jacks.

The audio playback (AUDIO LINE OUT) jacks of the VCR go to the TAPE PB jacks, and the audio record (AUDIO LINE IN) jacks go to the REC OUT jacks.

● Monitor TV

Connect the video jack from a monitor to the MONI OUT jack.

Note that the audio connections to the monitor are not necessary as the audio portion of the signal is sent to your speakers through the receiver.

● **S VIDEO connectors**

* When a VCR that has S connectors is used, connect the S VIDEO connectors. With the S VIDEO connections, a high resolution picture will be obtained, resulting in a much clearer reproduction. Connect the S output connector of the VCR to the S VIDEO IN connector in the VCR 1 section on the rear panel of this unit, and connect the S input connector of the VCR to the S VIDEO OUT connector.

* Keep the VCR IN and OUT jacks, and audio IN and OUT jacks connected between the VCR and this unit.

If the second VCR has S connectors, connect the S output and input connectors to the S VIDEO IN and OUT connectors in the VCR 2 section on the rear panel of this unit in the same way.

* When a monitor that has an S video connector is used, connect S VIDEO MONITOR OUT connector. With the S VIDEO connections, a high resolution picture will be obtained, resulting in a much clearer reproduction.

Note

If signals from the VCR are not input to this unit through the S connector, there is no signal output at the S VIDEO MONI OUT connector. Because the VIDEO SIGNAL IN and OUT jacks and the S VIDEO IN and OUT connectors have separate built-in circuits, there must be a connection to the S VIDEO IN and OUT connectors when signals are to be output to the S VIDEO MONI OUT connector.

In addition, the circuits for the VIDEO SIGNAL IN and OUT jacks and the S VIDEO SIGNAL IN and OUT connectors are linked when "VCR" is selected as the source by using the input selector.

When the VCR is connected to both the VIDEO SIGNAL IN jack and the S VIDEO IN connector, signals will be output to both S VIDEO MONI OUT and VIDEO MONI OUT, so select (at the monitor) which signal is to be monitored.

● **Other audio component**

For extra system flexibility, this unit allows you to connect a signal processing system, such as graphic equalizer, sound processor, etc., in the signal path prior to the tone control circuitry. To connect these units, pull out the jumper pins from the PRE OUT/MAIN IN jacks, connect the inputs of the unit to the PRE OUT jacks and outputs to the MAIN IN jacks. For details, refer to the Owner's Manual attached to the unit to be connected.

● **Remote control cable**

The REMOTE CONTROL connectors are used when you have YAMAHA compatible components (with an *SRMS* mark).

These connections allow you to control the components from the supplied remote control transmitter.

Connect the remote control cables from the components to the correct connectors on your receiver (i.e. PHONO, TAPE).

Note that no cable is necessary for a compatible CD player, or a compatible cassette deck which has a remote control sensor as the remote control transmitter operates the player directly.

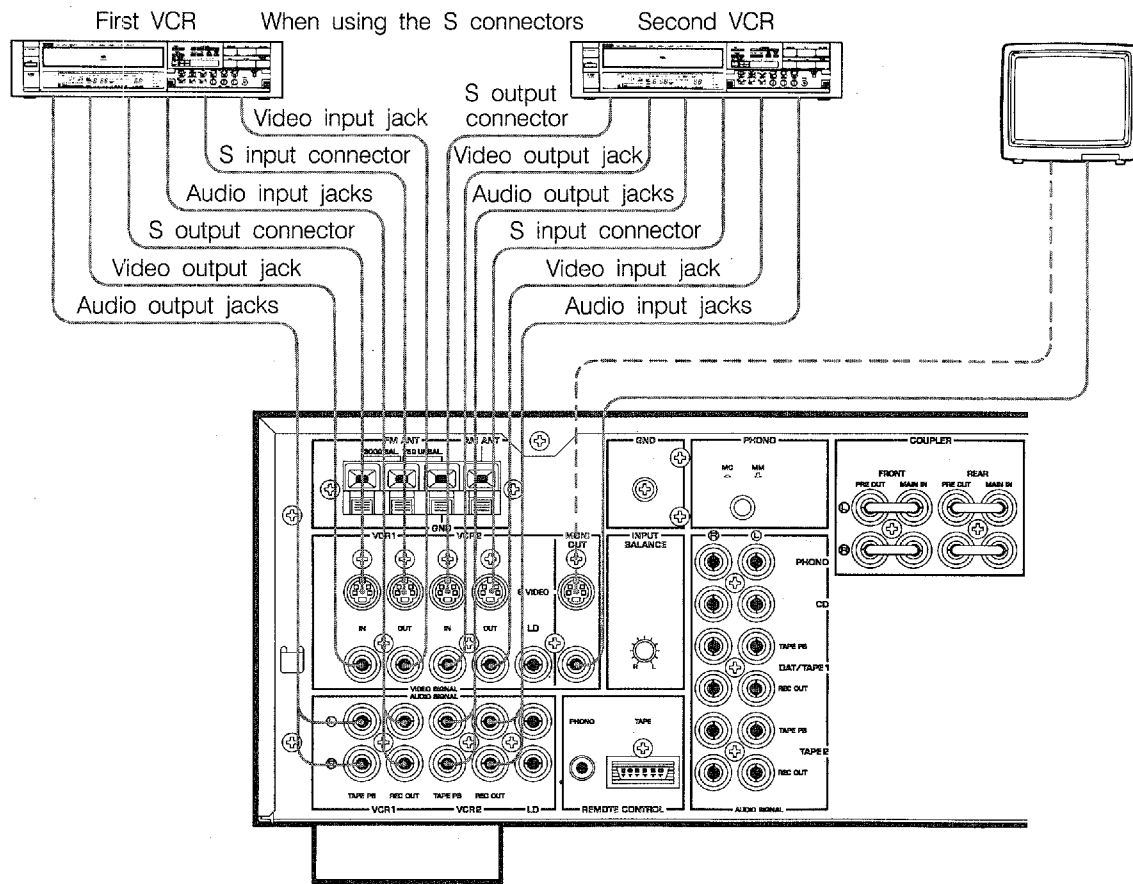

TO LISTEN TO RADIO PROGRAM

Auto Tuning

If signals are strong and there is no interference, quick automatic search tuning is possible.

1. Select the tuner source with the INPUT SELECTOR.
 2. Select the reception band with FM/AM button.
 3. Press the TUNING MODE button so that the AUTO TUNING indicator lights up.
 4. Select the IF mode with the IF MODE button.
 5. Use the TUNING button to tune.
The tuning will start automatically and stop at broadcast station frequency with a sufficient signal strength.
 6. If the station where tuning stops is not the one you want, press the TUNING button once again.
 7. Adjust the VOLUME control, TONE controls, etc.
- When an FM stereo broadcast with a sufficient signal strength is received, the STEREO indicator lights.
 - When the received station is locked with the computer servo lock system, the CSL indicator lights.

Technical notes on the Computer Servo Lock (CSL) system

The new YAMAHA Computer Servo Lock Tuning system eliminates many conventional tuning problems by effectively providing two different tuning modes, each optimized for different types of reception conditions, and both controlled by a sophisticated microprocessor. The microprocessor discriminates between different reception conditions and selects the appropriate tuning mode according to the quality of the received signal. If the station has a strong, high quality signal, an infinite resolution FM stereo tuning circuit is used for maximum audio quality. With a weak, poor quality signal, the PLL tuning mode locks on to the broadcast frequency to ensure the best possible reception.

Manual Tuning

Auto tuning may be impossible if the station signal is weak. If so, use manual tuning.

1. Select the tuner source with the INPUT SELECTOR.
2. Select the reception band with FM/AM button.
3. Press the TUNING MODE button so that the AUTO TUNING indicator goes off.
4. Select the IF mode with the IF MODE button.
5. Use the TUNING button to tune.
The frequency will change rapidly if the TUNING button is kept pressed. Release it slightly before reaching the desired frequency, and then press it intermittently until the desired frequency is reached. Use the FINE TUNING button to tune in the station precisely.

• Fine Tuning

Rapid tuning is usually possible with the Auto or Manual Tuning method, but more stabilized reception is possible with Fine tuning in the follows situations.

- * To receive a weak or very badly fading broadcast signal from among many signals
- * To receive a weak or medium-strength signal which is near a strong signal
- * If beat noise is received

In these instances, Manual Tuning and then Fine Tuning can be used to reduce noise and distortion. Set the TUNING MODE button to MAN'L MONO, and then press the FINE TUNING button, so that the FINE TUNING indicator lights.

The best reception can be easily obtained by using the SIGNAL QUALITY indicators during fine tuning.

Preset Tuning

The preset station button can be used to select, at a single touch, any desired station which has been preset.

1. Tune to the desired station using auto or manual tuning mode.
2. Select the range of the preset station button with the P1-P8/P9-P16 button.
3. Press the MEMORY button and then while the MEMORY indicator is flickering, press the desired preset station button.

Note

If tuning is done in the manual mode and then MEMORY button is pressed, the preset tuning will be in Mono. Therefore prior to pressing MEMORY button, the tuning should be set to AUTO.

4. To receive the preset station, select the range of the preset station with the P1-P8/P9-P16 button and press the desired preset station button.
- Follow the same procedure for other preset station buttons.
 - The new setting will be programmed in place of the former one.
 - The settings of the IF MODE button, TUNING MODE button and FINE TUNING button are also preset.

Memory back-up

The memory back-up circuit will prevent the programmed information from being lost even though the power is switched OFF for timer use or other temporary power failure. If, however, the unit is not used for a long time, the memory may be erased. If so, it can be re-programmed by simply following the original procedure.

TO PLAY PROGRAM SOURCE

1. Select the program source to be heard with the INPUT SELECTOR.
2. Play the program source.
3. Adjust the VOLUME and tone controls.

* For details of the surround mode, refer to "USING THE SURROUND SOUND PROCESSOR" on page 17.

TO RECORD PROGRAM SOURCE

1. Select the program source to be recorded with the REC OUT selector.
2. To listen to the program source to be recorded, press the left or right side of the INPUT SELECTOR.
3. Play the program source to be recorded and set the tape deck or video cassette recorder to record mode.
4. To listen to other program source during recording, select the program source to be listened to with the INPUT SELECTOR.

When your tape deck has three head monitoring capability, select the corresponding tape source with the INPUT SELECTOR to listen to just recorded signal. The settings of the SURROUND MODE selector, tone controls, VOLUME control and TONE BYPASS switch do not affect the recording.

TO DUB AUDIO TAPES

1. Set the REC OUT selector to select the program source (DAT/TAPE 1, TAPE 2, VCR 1 or VCR 2) to be dubbed.
2. To listen to the program source to be recorded, press the left or right side of the INPUT SELECTOR.

3. Set the tape decks or video cassette recorders to play and record mode respectively.
4. To listen to other program source during dubbing, select the program source to be listened to with the INPUT SELECTOR.

When your tape deck has three head monitoring capability, select the corresponding tape source with the INPUT SELECTOR to listen to just recorded signal. The settings of the SURROUND MODE selector, tone controls, VOLUME control and TONE BYPASS switch do not affect the dubbing.

TO RECORD VIDEO SOURCES

1. Select the desired program source to be recorded with the REC OUT selector.
2. Set the VCR for recording to the record-pause mode.
3. Play the video source to be recorded and start recording with the recording VCR at the same time.

TO DUB VIDEO TAPES

1. Set the REC OUT SELECTOR to select the program source to be dubbed.
2. Set the video cassette recorders to play and record mode respectively.
3. To listen to other program source during dubbing, select the program source to be listened to with the INPUT SELECTOR.

The settings of the SURROUND MODE button, tone controls, VOLUME control and TONE BYPASS switch do not affect the dubbing.

TIPPING THE OPERATION PANEL

The operation panel, which is located at the lower side of the front panel, may be tipped in and out. When it is not necessary to operate buttons or controls on this panel you may tip this panel back inside the unit, as shown in the figure.

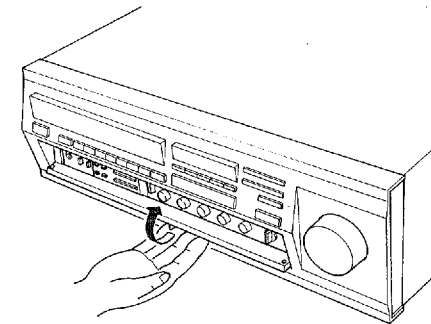

When the operation panel is desired, tip it toward you, as shown in the figure.

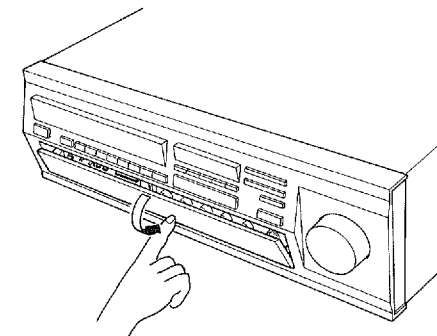

USING THE SURROUND SOUND PROCESSOR

This unit incorporates a sophisticated, multi-mode digital surround sound processing amplifier, which allows you to expand and shape the audio sound field from both the audio and video sources, for a theater-like experience in the listening/viewing room.

The surround sound processor has 5 processing modes and an independent DELAY TIME button which functions in conjunction with five of the surround modes. There are four modes for stereo sources. One mode for monaural sources is also included.

* When using the surround sound processor, be sure that the CD DIRECT SWITCH is set to OFF.

SURROUND MODES

1 NATURAL SUR.

The original YAMAHA Natural Surround mode is used to create a surround effect for video signals not encoded in Dolby Surround. Background and reverberant sounds are sent solely to the rear speakers. This mode is especially effective with programs that have a lot of reverberation. The acoustic image center is firmly located and centered between left and right front speakers.

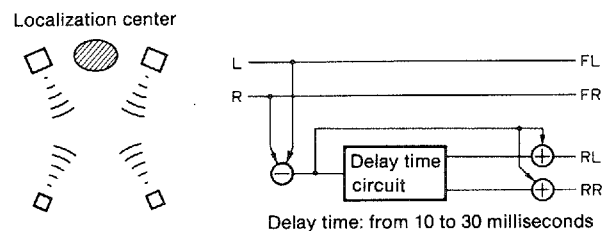

2 HALL SURROUND

In this mode, the center seems even more deeply behind the front speaker pair, creating an expansive, large hall ambience. The apparent listening position is in the center of the hall rather than in front of the stage.

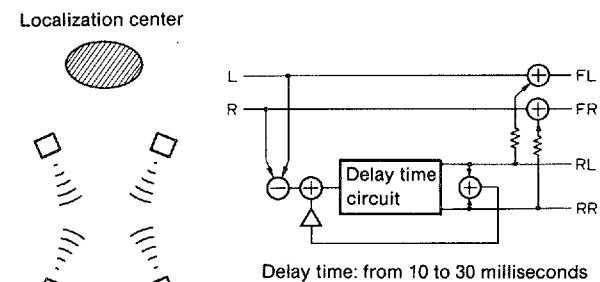

3 DOLBY SURROUND

Dolby surround effect is encoded on the sound track of many commercially available video cassettes, video discs, etc. To play these program sources, use this mode. When you play program sources encoded with Dolby surround, Dolby surround mode of this unit decodes the signal and feeds the sound effect through your rear speakers.

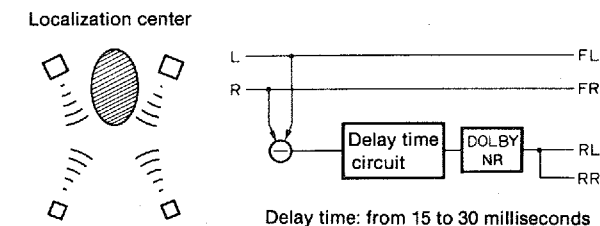

DOLBY SURROUND™

Manufactured under license from Dolby Laboratories Licensing Corporation. Additionally licensed under one or more of the following patents: U.S. numbers 3,632,886, 3,746,792, and 3,959,590; Canada numbers 1,004,603 and 1,037,877. "Dolby" and the double-D symbol are trademarks of Dolby Laboratories Licensing Corporation.

4 SIMULATED STEREO

This mode was designed specifically to enhance mono source programs. Compared to a strictly mono setting, the sound image created in this mode is wider and slightly forward of the speaker pair, lending an immediacy to the overall sound. It is particularly effective when used with old mono movies, news broadcasts and dialogue.

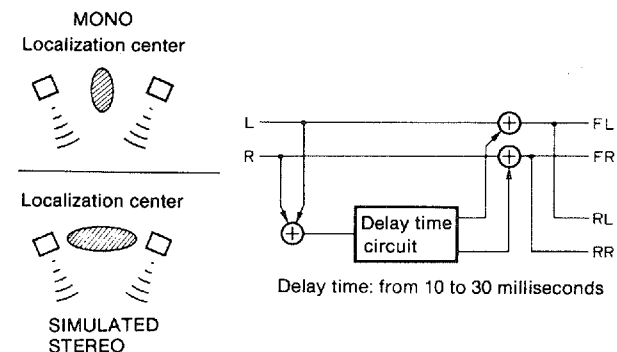

5 LIVE SURROUND

This mode takes advantage of the delay signal and a feedback circuit on the rear effect speakers to create a bright, lingering, and somewhat resonant sound that characterizes a small concert space.

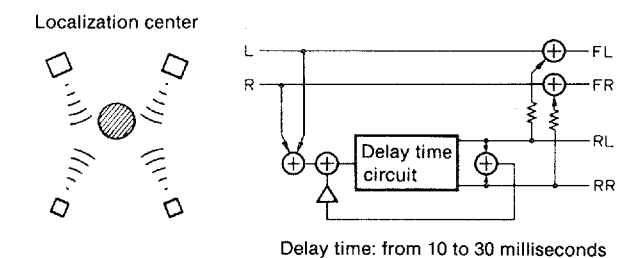

● DELAY TIME UP/DOWN control

The DELAY TIME control is effective with all modes. It provides for continuously variable control over the delay time.

- 1 NATURAL SUR.: from 10 to 30 milliseconds
- 2 HALL SURROUND: from 10 to 30 milliseconds
- 3 DOLBY SURROUND: from 15 to 30 milliseconds
- 4 SIMULATED STEREO: from 10 to 30 milliseconds
- 5 LIVE SURROUND: from 10 to 30 milliseconds

By applying more or less delay, sound effects, background noise, and ambient noise coming at you from the rear speakers can be enhanced or subdued for extra effect. Adding too much delay will cause an unnatural effect with some sources. Experiment with the DELAY TIME UP/DOWN control to create an effect that you find most suitable.

- * The last setting of the DELAY TIME control is memorized even when the power is turned off.
- * The surround sound processor is effective only when this unit is used in a 4-speaker system setup. Refer to the "REAR SPEAKER REPLACEMENT" described later.

REAR SPEAKER PLACEMENT

(See Fig. 5.)

The placement of a rear speaker pair in the listening room will greatly affect the overall sound field created. A small pair of speakers is all that is really required to create the full effect, and the most basic speaker placement configuration is the one shown in Fig. A. This setup is ideal for creating a theater-like atmosphere for movies and other video programs.

The "B" setup creates a sound field with added depth, much like that experienced in a live concert hall, where all the sound is coming at you from the front. It is most appropriate for musical sources, rather than videos.

The "C" speaker placement configuration effectively "widens" the sound field, and is suitable for movies and other video programs.

While the most basic speaker placement setup is recommended at first, by experimenting with different speaker placements for each musical or video source, and with each surround mode, you will be able to create a wide variety of sound field effects suited to your listening environment, and to your own particular tastes.

INPUT BALANCE CONTROL ADJUSTMENT

To obtain the best surround condition, be sure to adjust the rear panel INPUT BALANCE control.

1. Set the front panel controls as follows.
 - SPEAKERS (for the front setting) selectors – Set to "OFF".
 - SURROUND ON/OFF switch – Set to ON.
 - SURROUND MODE buttons – Select the "DOLBY SUR." mode.
 - REAR LEVEL control – Set to the "10" (maximum) position.
2. Set the INPUT BALANCE control on the rear panel to the center position.
3. Play a monaural program source.
4. Turn up the VOLUME control so that you can hear the monaural program source through the rear speakers.
5. Then minimize the rear speakers' output by slightly turning the INPUT BALANCE control clockwise or counterclockwise until you achieve a "null" (ie., minimum output from your rear speakers).
NOTE: As you approach the "null", turn up the VOLUME control to better hear your rear speakers.

With this adjustment, the best surround balance can be obtained.

OPERATION

1. Set the SURROUND ON/OFF switch to ON.
2. Play the program source.
3. Select the surround mode with the SURROUND MODE buttons.
4. Adjust the REAR LEVEL control.
5. Use the VOLUME control to adjust the whole sound level.
6. Use the DELAY TIME control to adjust the audio sound delay time.

REMOTE-CONTROL TRANSMITTER

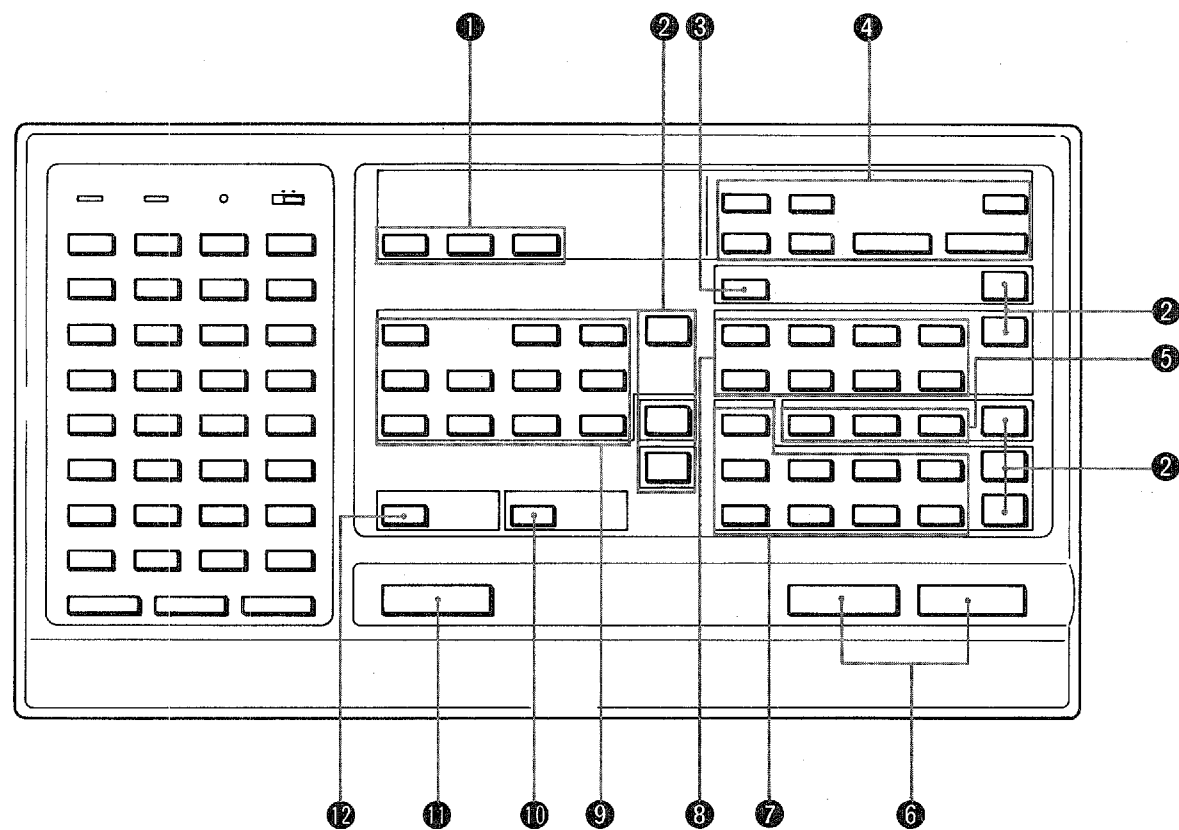

■ CONTROLS AND THEIR FUNCTIONS

The remote control transmitter supplied with your receiver is designed to control all the most commonly used features of the receiver. If the CD player, CDV/Video disc player, turntable, cassette deck and graphic equalizer connected to your receiver are YAMAHA components designed for remote control compatibility (components with an  mark), then this remote control transmitter will also control various functions of each component. Please consult your YAMAHA dealer for information on which components are compatible with the remote control transmitter. Note that any compatible YAMAHA CD player, CDV/Video disc player or a compatible YAMAHA cassette deck which has a remote control sensor, can be directly operated by this remote control transmitter.

① Graphic-equalizer keys

These keys can be used for operation of a YAMAHA graphic-equalizer (such as model EQ-630, etc.) if it includes the presetting function.

EQ ON/FLAT key

This key can be used to select whether or not to use the circuitry of a graphic-equalizer connected to the receiver.

PRESET UP/DOWN keys

These keys can be used to select any of the preset "channels".

② Input selector keys

These keys are used to select the sound source.

③ PLAY/CUT key

This key can be used to start or stop disc play on a turntable (with the  mark) connected to the receiver. This key functions in the same manner as the PLAY/CUT key on the turntable itself. Press it once to start play, and once again to stop play.

④ SURROUND key

DELAY TIME UP/DOWN keys

These keys have the same function as the DELAY TIME control on the receiver.

ON/OFF key

This key has the same function as the SURROUND ON/OFF switch on the receiver.

SURROUND MODE UP/DOWN keys

These keys are used to select the SURROUND PROCESSING MODE. Press the UP key to increase the number of the SURROUND PROCESSING MODE. Press the DOWN key to decrease the number of the SURROUND PROCESSING MODE.

REAR LEVEL UP/DOWN keys

These keys have the same function as the REAR LEVEL volume control on the receiver.

⑤ Tuner keys

These keys are used to select one of the preset broadcast stations.

P1-P8/P9-P16 key

This key is used to select one of the two preset ranges: P1 – P8 or P9 – P16. The range changes alternately each time the key is pressed.

UP key

Press this key to select the desired station within the selected range. The preset ("P") number increases by one (example: P7 to P8) each time the key is pressed. If the key is pressed while the P8 (or P16) station is being received, P8 (or P16) will change to P1 (or P9).

DOWN key

Press this key to select the desired station within the selected range. The preset ("P") number decreases by one (example: P8 to P7) each time the key is pressed. If the key is pressed while the P1 (or P9) station is being received, P1 (or P9) will change to P8 (or P16).

⑥ VOLUME control keys

These keys are used to adjust the volume level heard from the speakers connected to this unit.

These keys also have the "learning" function. Refer to "ABOUT THE "LEARNING" FUNCTION" on page 22 for details.

⑦ Cassette tape deck keys

A cassette tape deck that bears the RS mark can, when connected to the receiver, be controlled by using this remote-control transmitter.

DECK A/B key

Press this key to select either deck A or deck B if the cassette deck connected is a double-cassette deck.

◀◀ key

Press this key to rewind the tape.

▶▶ key

Press this key to start tape playback. If the deck connected is a double-cassette deck, the tape in the deck that played back most recently will begin playback when this key is pressed.

▶▶ key

Press this key to fast-forward the tape.

REC/PAUSE key

Press this key to set the cassette tape deck to the recording-pause mode.

STOP key

Press this key to stop the tape movement.

REC MUTE key

Press this key to make a non-recorded space on the tape while a recording is in progress.

DIR A key (for use with a double-cassette deck only)

Press this key to change the direction of movement of the tape in cassette tape deck A.

DIR B key (for use with a double-cassette deck only)

Press this key to change the direction of movement of the tape in cassette tape deck B.

⑧ Compact-disc player keys

A YAMAHA compact-disc player that bears the *RS* mark can, when connected to the receiver, be directly controlled by using this remote-control transmitter.

SKIP ▶▶▶ key

Press this key to advance to the beginning of the next track on the disc.

SKIP ◀◀◀ key

Press this key to return to the beginning of the track now playing.

If this key is pressed at the beginning of a track, play will begin from the beginning of the previous track.

SEARCH ▶▶▶ key

Press this key to advance rapidly.

SEARCH ◀◀◀ key

Press this key to move rapidly in the reverse direction.

DISC UP/DOWN keys

These keys are used for selection of the disc, and are applicable only to compact-disc players that have the magazine type of automatic disc-changing mechanism.

PAUSE/STOP key

This key is used to stop (or temporarily stop: pause) the compact-disc player operation.

Play stops temporarily when the key is pressed once, and changes to a complete stop when the key is pressed again.

PLAY key

Press this key to start compact-disc play.

⑨ CDV/Video disc player keys

A YAMAHA compact-disc/video disc player (such as model CDV-1600, CDV-2000, etc.) that bears the *RS* mark can, when connected to the receiver, be directly controlled by using this remote-control transmitter.

OPEN/CLOSE key

Press this key to open or close the disc tray.

PAUSE/STOP key

Press this key once to temporarily stop the CDV player operation; when it is pressed again, the CDV player changes to the stop mode.

PLAY key

Press this key to start the CDV disc or video disc play.

CHAPTER keys

- + When this key is pressed during CDV disc or video disc play, the beginning of the next "chapter" is detected.
- When this key is pressed during CDV disc or video disc play, the beginning of the "chapter" now playing is detected.

SEARCH keys

- ▷ When this key is pressed during CDV disc play, compact-disc play, or video disc play, play is advanced at high speed.
- ◁ When this key is pressed during CDV disc play, compact-disc play, or video disc play, play is reversed at high speed.

STILL keys (CAV)

- ▷ This key is used to display a still picture or for frame-by-frame play in the forward direction during video (CAV) disc play.
- ◁ This key is used to display a still picture or for frame-by-frame play in the reverse direction during video (CAV) disc play.

SOUND select key (Video disc)

This key can be used to select the sound to be played from the disc and which will be output from the left and right audio signal output jacks.

The selected audio signal changes in the order: STEREO → 1/L-CH → 2/R-CH each time the key is pressed.

DISPLAY key

When this key is pressed during the play of a video (CAV) disc, the "chapter" and frame numbers of the picture now being viewed are displayed on the screen. When this key is pressed during the play of a video (CLV) disc, the "chapter" number and the time are displayed on the screen.

When this key is pressed during the play of a compact disc or a CDV disc, the total time, remaining time or track time is displayed on the screen.

⑩ MUTING (-20 dB) key

Press this key to mute the sound level by 20 dB. Press the key again to resume original sound level. This key is very convenient for lowering the volume level temporarily (for instance, to answer a phone call) without disturbing the original volume level setting.

⑪ POWER key

Press this key to turn the power of receiver ON and OFF.

⑫ SLEEP key

The power to the receiver is automatically switched OFF one hour after this key is pressed.

■ BATTERY INSTALLATION/REPLACEMENT

- Install the batteries as shown below.

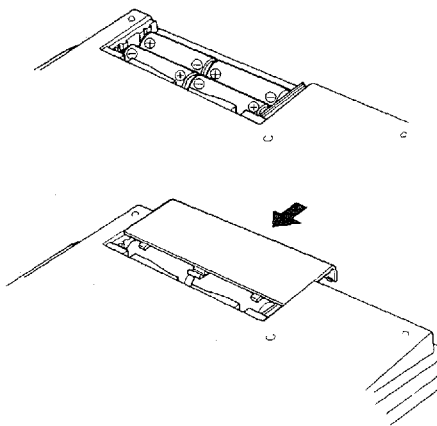

- Be sure to follow the diagram in the battery compartment to assure proper positive (+) and negative (-) polarity.
- Do not use old and new batteries at the same time.
- If a battery leaks, dispose of all batteries; then clean the battery compartment thoroughly before installing new batteries.

■ OPERATION RANGE

The remote-control transmitter must be faced toward the component to be controlled, and be within a range of about 7 meters (23 feet) for proper operation.

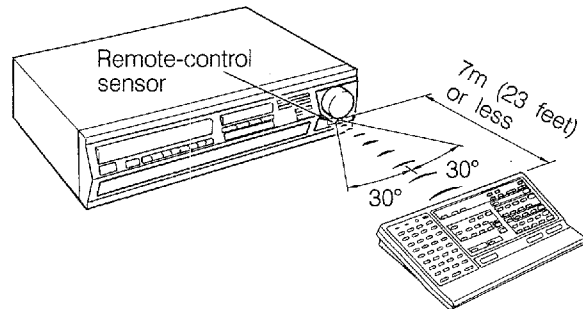

■ ABOUT THE "LEARNING" FUNCTION

This remote-control transmitter has a number of programmable keys.

These keys can be programmed to "learn" the signal patterns from other remote-control transmitters. By programming this unit with the signals from other remote-control transmitters, this unit can then be used in place of one or more other remote-control transmitters, thus making operation of your various audio and video components more convenient.

NOTE

There may occasionally be instances in which, due to the signal-coding and modulation systems employed by the other remote-control transmitter, that this unit will not be able to "learn" its signals.

IDENTIFICATION OF PARTS

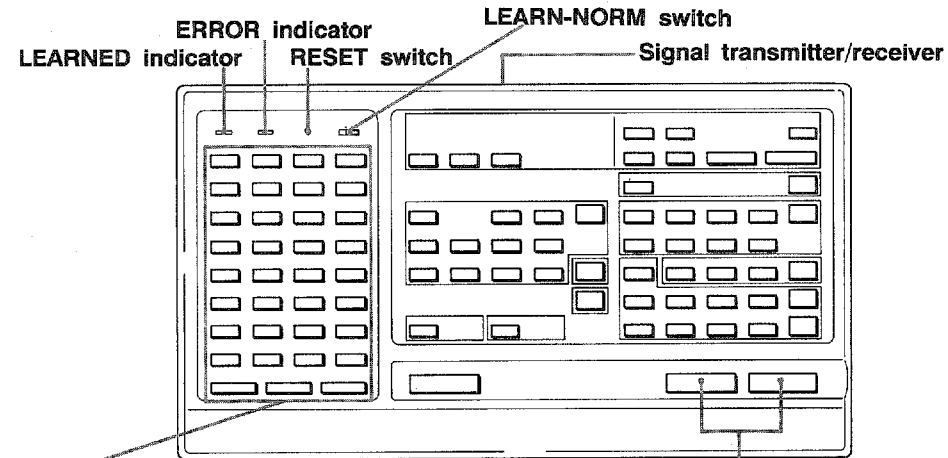

Learning keys

These keys can be used to "learn" (program) signals from other remote-control transmitters.

Programmable preset learning keys

These keys have already been preset with signals for controlling the volume of the receiver, but, if desired, other signals can be "learned" by these keys (over the preset signals), in the same way as the ordinary learning keys.

(The "learning" method is the same as that for the ordinary learning keys.)

* These keys are convenient for programming signals for use as the master volume control of a YAMAHA digital-sound-field processor (model DSP-3000, DSP-1, etc.) and so on.

TO PROGRAM SIGNALS FROM OTHER REMOTE-CONTROL TRANSMITTERS

Before programming

- Some learning keys are larger than others, but all keys are potentially capable of the same functions if so programmed. Keys should be programmed and used according to their positional convenience.
- Use the included seals to indicate the functions for which learning keys have been programmed. It is recommended that you first determine the best and most convenient layout of the keys for the various functions you plan to program (and attach the seals accordingly), and then program the keys correspondingly.

Follow the steps described below to program signals from other remote-control transmitters to this unit.

- Set the LEARN-NORM switch to the "LEARN" position.

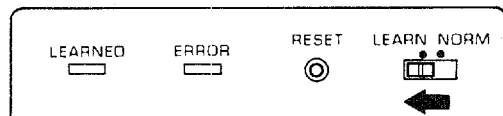

- Position this unit and the other remote-control transmitter head to head.

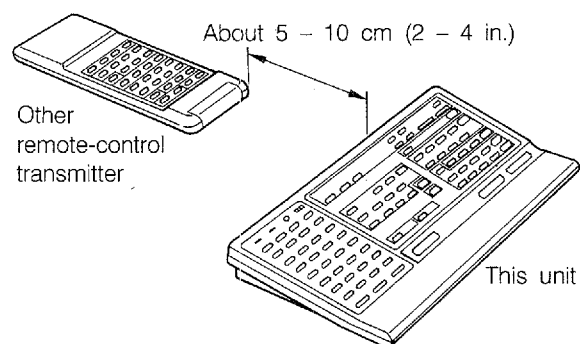

- Press the learning key (or programmable preset learning key) on this unit to which the programming will be made.

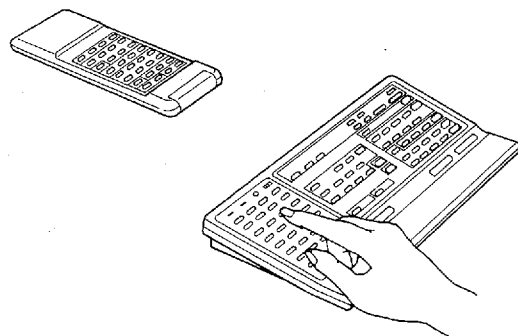

- If the pressed key is unprogrammed, the LEARNED indicator will flash continuously. If the key is already programmed, the LEARNED indicator will flash continuously and, at the same time, the ERROR indicator will illuminate. Then proceed to the next step if you want to change that instruction already programmed for the key. If you do not want to change it, however, press the key to be programmed next and proceed to the "learning" operation of that key.

- Press the key (on the other remote-control transmitter) for the function to be programmed.

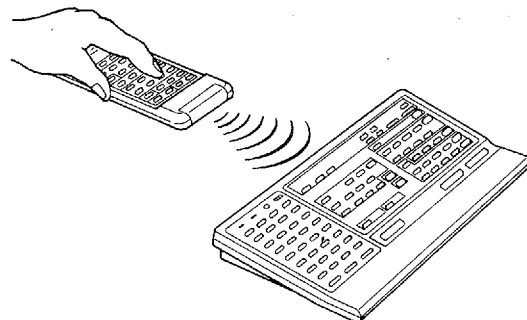

- The LEARNED and ERROR indicators will illuminate continuously while the signals from the other remote-control transmitter are being received by this unit. Press and hold the key on the other remote-control transmitter until the illumination of these indicators stops. The LEARNED indicator will illuminate for about two seconds when the programming of signals has been successfully completed.

- Repeat steps 3 and 4 until the signals for all programmings you want to make are successfully programmed.

- After all programming is completed, set the LEARN-NORM switch to the "NORM" position.

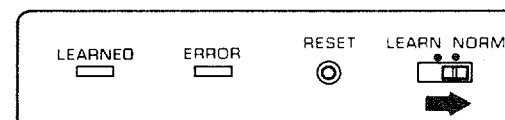

After all programming is completed, try operating this unit.

Notes

- Note that the successful programming of signals to a learning key results in the erasure of previously programmed signals and their replacement by the newly programmed signals.
- In step 4, If the key on the other remote-control transmitter is not pressed within 15 seconds after a learning key is pressed, this unit will automatically return to the status that was in effect before the learning key was pressed.

- If the signals are not successfully programmed to this unit, the ERROR indicator will flash for about two seconds. If signals to be programmed are too long and this unit cannot program them, this unit automatically expands the work area capacity to be doubled, and will then await the next entry. During this stand-by mode the LEARNED indicator flashes rapidly. If this happens, try programming again.
- Although, because this unit employs the variable length programming method, long signals can also be programmed, if all signals programmed are long signals, it might happen that the capacity of the memory area would be completely used before all keys that are programmable are actually programmed, and no further programming would be possible. If this happens, after the signals from the other remote-control transmitter is received (in step 4), the LEARNED indicator and the ERROR indicator will flash two times.

Memory back-up

All of the programmed functions will be retained while you replace the batteries. However, if no batteries are installed for a few hours, the memory will be erased and will have to be programmed again.

Trouble shooting guide

- If programming cannot be made successfully, or if this remote-control transmitter does not function even though the programming was successful, check the following points:
 - * Check whether the batteries of the other remote-control transmitter are weak. Note that even though its batteries may be strong enough to operate the component it was made for, they may be too weak to transfer signals to this unit. If so, replace the batteries of the other remote-control transmitter.
 - * Check whether the distance between the two remote-control transmitters is too long or too short.

- * Check whether a strong light, such as direct sunlight, is striking the signal transmitter/receiver of this unit.
- The remote-control transmitter's batteries are too weak if the LEARNED indicator and the ERROR indicator do not illuminate or flash, or if the distance or range within which the remote-control transmitter can be used decreases. If either occurs, replace the batteries with new ones.

HOW TO CLEAR SIGNALS PROGRAMMED BY THE LEARNING OPERATION

By using the RESET switch, signals that you have programmed to a learning key or to a programmable preset learning key can be canceled.

For a programmable preset learning key, there is a return to the originally preset commands for volume control of the receiver when this switch is pressed.

1. Set the LEARN-NORM switch to the "LEARN" position.

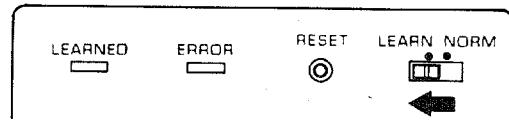

2. Press the RESET switch using the point of a mechanical pencil, etc. The LEARNED and ERROR indicators will illuminate for 15 seconds.

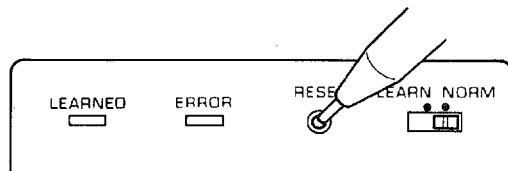

3. Press and then release the learning key (or programmable preset learning key) for which you want the programmed signal to be canceled. The LEARNED indicator's illumination and the ERROR indicator's illumination will then stop. Then, when the cancellation is finished, the LEARNED indicator will illuminate for one second. This indicates the completion of the cancellation process. To cancel two or more programmings, repeat steps 2 and 3.

Note

If a learning key (or a programmable preset learning key) is not pressed within 15 seconds after the RESET switch is pressed, this unit will automatically return to the status that was in effect before the RESET switch was pressed.

REMOTE-CONTROL OPERATION

Note the following points when using this unit for operation of audio/video-equipment.

- Be sure to set the LEARN-NORM switch to the "LEARN" position.
- If this unit is faced toward the component to be operated and the key pressed correctly so that the correct signal can be transmitted, the LEARNED indicator will illuminate steadily. The ERROR indicator will illuminate if an unprogrammed key is pressed, or two or more keys are pressed simultaneously or one after another.
 - * If a short signal is transmitted by a learning key, this indicator's illumination will stop when signal transmission ends, even if the key is pressed for a longer time.

TROUBLESHOOTING

If the unit fails to operate normally, check the following points to determine whether the fault can be corrected by the simple measures suggested. If it cannot be corrected, or if the fault is not listed in the SYMPTOM column, disconnect the power cord and contact your dealer or service center for help.

	SYMPTOM	CAUSE	REMEDY
Amplifier	The receiver fails to turn on when the POWER switch is pressed.	Power cord is not plugged in or is not completely inserted.	Firmly plug in the power cord.
	No sound.	Incorrect output cord connections.	Connect cord properly. If the problem persists, the cables may be defective.
		Incorrect receiver operation.	Set the receiver controls to the correct input selection.
	Sound "hums".	Incorrect cord connections.	Firmly connect the audio plugs. If the problem persists, the cord may be defective.
FM	No picture.	Incorrect cord connections. Wrong video unit selected. Video unit not turned on.	Connect the video plugs correctly. Select correct video unit. Turn video unit on.
	FM stereo reception is noisy.	Because of the characteristics of FM stereo broadcasts, this is limited to cases where the transmitter is far away or the antenna input is poor.	Check the antenna connections. Try using a multiple element FM antenna.
	There is distortion and clear reception cannot be obtained even with a good FM antenna.	There is multipath interference.	Adjust antenna placement to eliminate multipath interference.
	A desired station cannot be tuned in with Auto tuning.	The station is too weak.	Use Manual tuning mode. Use high quality directional FM antenna.
AM	A desired station cannot be tuned in with Auto tuning.	Weak signal or loose antenna connections.	Tighten the AM loop antenna connections and rotate it for best reception. Use Manual tuning mode.
	There are continuous crackling and hissing noises.	These noise result from lightning, fluorescent lamps, motors, thermostats and other electrical equipment.	Use an outdoor antenna and a ground wire. This will help some what but it is difficult to eliminate all noise.
	There are buzzing and whining noises (especially in the evening).	A television set is being used nearby.	Move the television away.

SPECIFICATIONS

AUDIO SECTION

Minimum RMS Output Power per Channel (Front)	
8 ohms, 20 Hz to 20 kHz, 0.015% THD	125 W
6 ohms, 20 Hz to 20 kHz, 0.03% THD	145 W
Output Power per channel (Rear)	
8 ohms, 1 kHz, 0.08% THD	30 W
Dynamic Power per Channel (IHF)	
8/6/4/2 ohms	180/220/280/360 W
Dynamic Headroom	
8 ohms	
[U.S.A. and Canada models]	1.58 dB
Power Band Width	
8 ohms, 62.5 W, 0.1% THD	10 Hz to 50 kHz
Damping Factor	
8 ohms, 1 kHz	60
Input Sensitivity/Impedance	
PHONO MC	160 μ V/220 ohms
PHONO MM	2.5 mV/47 k-ohms
CD/VIDEO/TUNER/AUX/TAPE/VCR	150 mV/47 k-ohms
MAIN IN	1 V/82 k-ohms
REAR	150 mV/470 k-ohms
Input Sensitivity (New IHF)	
[U.S.A. and Canada models]	
PHONO MC	14 μ V
PHONO MM	0.22 mV
CD/VIDEO/TUNER/AUX/TAPE/VCR	13.4 mV
Maximum Input Signal (1 kHz, 0.01% THD)	
PHONO MC	7.5 mV
PHONO MM	110 mV
Output Level/Impedance	
REC OUT	150 mV/470 ohms
PRE OUT	1 V/1.7 k-ohms
Maximum Voltage Output	
(20 Hz to 20 kHz, 0.01% THD)	
PRE OUT	2.5 V

Headphone Jack Rated Output/Impedance	
8 ohms, 0.015 % THD	0.91 V/270 ohms
Frequency Response (20 Hz to 20 kHz)	
CD/VIDEO/TUNER/AUX/TAPE/VCR/MAIN IN	± 0.3 dB
RIAA Equalization Deviation	
PHONO MC (30 Hz to 20 kHz)	± 0.5 dB
PHONO MM (20 Hz to 20 kHz)	± 0.3 dB
PHONO MM (10 Hz to 100 kHz)	± 0.5 dB
Total Harmonic Distortion (20 Hz to 20 kHz)	
PHONO MC to REC OUT (1.5 V)	0.005%
PHONO MM to REC OUT (1.5 V)	0.003%
CD/VIDEO/TUNER/AUX/TAPE/VCR to SP OUT	0.009%
(62.5 W/8 ohms)	0.007%
MAIN IN to SP OUT (62.5 W/8 ohms)	0.007%
Signal-to-Noise Ratio (IHF-A Network)	
PHONO MC (500 μ V Input Shorted)	75 dB
PHONO MM (5 mV Input Shorted)	92 dB
CD/VIDEO/TUNER/AUX/TAPE/VCR (Shorted)	98 dB
MAIN IN (Shorted)	120 dB
CD DIRECT	103 dB
Residual Noise (IHF-A Network)	
CD/VIDEO/TUNER/AUX/TAPE/VCR	200 μ V
CD DIRECT	120 μ V
Channel Separation (1 kHz, Vol. -30 dB)	
PHONO MC, MM (Input Shorted)	60 dB
CD/VIDEO/TUNER/AUX/TAPE/VCR	60 dB
(Input 5.1 k-ohms Terminated)	60 dB
Tone Control Characteristics	
BASS: Boost/cut	± 10 dB (50 Hz)
Turnover Frequency	350 Hz
TREBLE: Boost/cut	± 10 dB (20 kHz)
Turnover Frequency	3.5 kHz
MID: Control range	± 10 dB (1 kHz)
Center frequency	1 kHz
Continuous Loudness Control	-40 dB (1 kHz)
(Level related equalization)	
Audio Muting	-20 dB

VIDEO SECTION

Video Input	1.0 Vp-p, 75 ohms, Unbalanced
Video Output	1.0 Vp-p, 75 ohms Unbalanced
Maximum Input Level	1.5 Vp-p, 75 ohms
S Video Input	
	1 Vp-p, 75 ohms, Unbalanced (Input-Y)
	0.3 Vp-p, 75 ohms, Unbalanced (Input-C)
S Video Output	
	1 Vp-p, 75 ohms, Unbalanced (Output-Y)
	0.3 Vp-p, 75 ohms, Unbalanced (Output-C)

FM SECTION

Tuning Range	87.5 to 108.0 MHz
50 dB Quieting Sensitivity (IHF, 75 ohms)	
Mono	1.5 μ V (14.8 dBf)
Stereo	20 μ V (37.3 dBf)
Usable Sensitivity (75 ohms)	
(30 dB S/N Quieting, 1 kHz, 100% mod.)	
	0.75 μ V (8.8 dBf)
Image Response Ratio	45 dB
IF Response Ratio	90 dB
Spurious Response Ratio	70 dB
AM Suppression Ratio	55 dB
Capture Ratio	1.2 dB
Alternate Channel Selectivity	
NARROW	85 dB
Signal-to-Noise Ratio	
(IHF) Mono/Stereo	85/81 dB
Harmonic Distortion (1 kHz)	
Mono/Stereo	0.05/0.07%
Stereo Separation (1 kHz)	54 dB
Frequency Response	
30 Hz to 13 kHz	0 \pm 0.5 dB
20 Hz to 15 kHz	0 \pm 1.5 dB

AM SECTION

Tuning Range
[U.S.A. and Canada models] 520 to 1,620 kHz
[Australia models] 522 to 1,620 kHz
Usable Sensitivity 100 μ V/m
Selectivity 32 dB
Signal-to-Noise Ratio 50 dB
Image Response Ratio 40 dB
Spurious Response Ratio 50 dB
Harmonic Distortion 0.3%

AUDIO SECTION

Output Level/Impedance
FM (100% mod., 1 kHz) 500 mV/2.8 k-ohms
AM (30% mod., 400 Hz) 150 mV/2.8 k-ohms

GENERAL

Power Supply
[U.S.A. and Canada models] AC 120 V, 60 Hz
[Australia models] AC 240 V, 50 Hz
Power Consumption
[U.S.A. and Canada models] 720 VA 570 W
[Australia models] 380 W
AC Outlets
[U.S.A. and Canada models]
Switched x 2 total 80 W max.
Unswitched x 1 200 W max.
[Australia models]
Switched x 1 80 W max.
Dimensions (W x H x D) 435 x 156 x 448.5 mm
(17-1/8" x 6-1/8" x 17-11/16")
Weight 14.5 kg (31 lbs. 14 oz.)
Accessories AM loop antenna x 1
Indoor FM antenna x 1
Remote control cable (mini-plug) x 1
Remote control cable (6-pin) x 1
Remote control transmitter x 1
Battery x 4

Specifications subject to change without notice.

YAMAHA



YAMAHA CORPORATION
10-1, Nakazawa-cho, Hamamatsu, 430 Japan